

No.	F054-3360
ISSUED:	Aug. 6, 2010
REVISED:	Dec. 14, 2015



HOSHIZAKI FLAKE ICE MAKER

**MODEL FM-750AKE(-SB)
FM-750AKE-N(-SB)
FM-1000AKE(-SB)
FM-1000AKE-N(-SB)**

**(F054, F054-C101, F054-C106, F054-C107
F055, F055-C101, F055-C106, F055-C107)**

PARTS LIST (HE)

D-0	JAN. 2014	K-1	AUG. 2010
D-1	JAN. 2014	A-3	AUG. 2011
E-0	JAN. 2015	B-0	JAN. 2012
E-2	SEP. 2015	B-1	APR. 2012
		C-0	JAN. 2013

List of Specifications

FM-750AKE	F054	Standard
FM-750AKE-SB	F054-C101	Chasiss : SUS304
FM-750AKE-N	F054-C106	Nugget type
FM-750AKE-N-SB	F054-C107	Nugget type, Chasiss : SUS304
FM-1000AKE	F055	Standard
FM-1000AKE-SB	F055-C101	Chasiss : SUS304
FM-1000AKE-N	F055-C106	Nugget type
FM-1000AKE-N-SB	F055-C107	Nugget type, Chasiss : SUS304

Auxiliary Codes

Auxiliary Code Breakdown

The auxiliary code is the first two characters in the serial number. The first character indicates the year. Years progress or regress in alphabetical order. The series runs from "A" through "V" and the letters "I" and "O" are skipped. The second character indicates significant part changes within a year. Base is "0" and this number advances for each change. In cases where there is a letter in parentheses, this designates the month. This is the last character in the serial number. The series runs from "(A)" through "(M)" and the letter "(I)" is skipped. This designation is only included when identifying a parts change within an auxiliary code.

Note About Ordering Parts

Most assemblies cannot be ordered as complete units; parts in the assemblies generally must be ordered separately.

FASTENER PART NUMBER

SCREWS

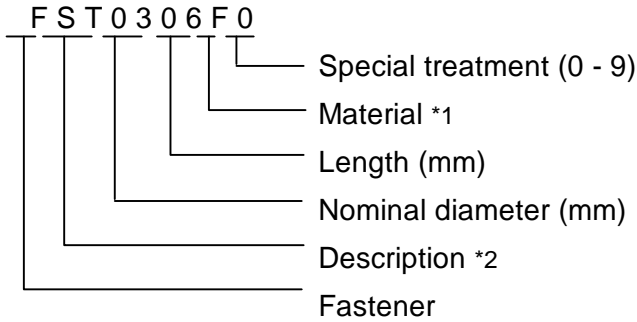

*1

- F: Steel
- S: Austenitic stainless steel
- M: Martensitic stainless steel
- B: Copper alloy
- P: Polycarbonate
- N: Polyamide
- V: PVC
- A: ABS
- X: Polyacetal
- L: Aluminum

NUTS & WASHERS

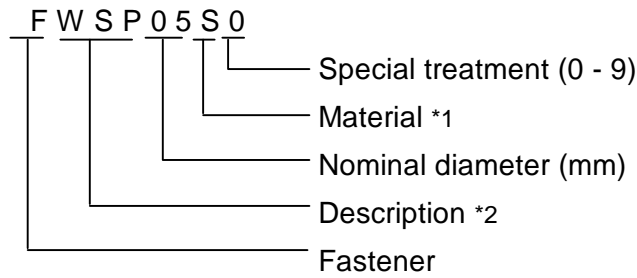

*2

- First letter
- S: Machine screw
- T: Tapping screw
- M: Wood screw
- B: Bolt
- W: Washer
- N: Nut

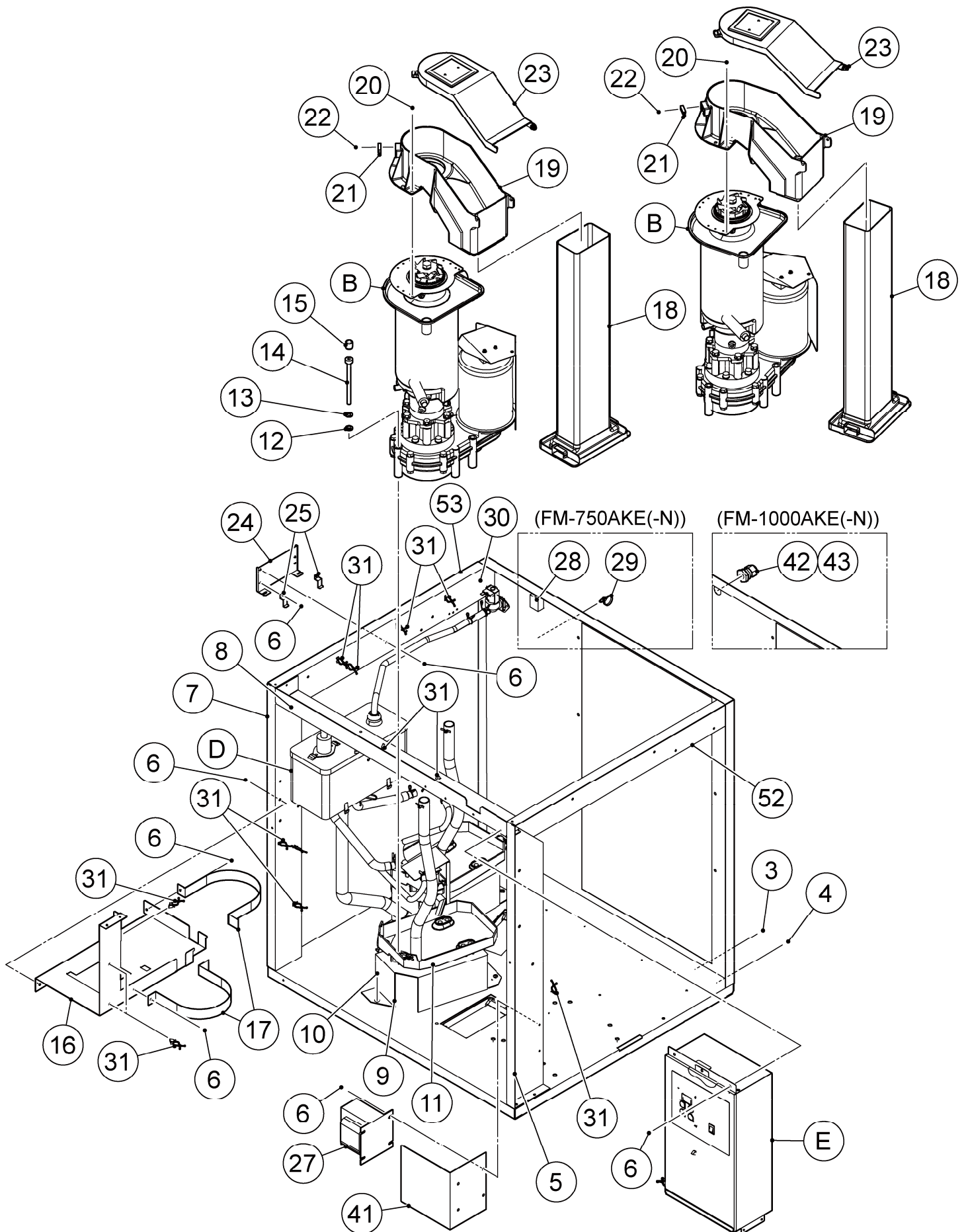

FM-750AKE(-SB)
FM-750AKE-N(-SB)
FM-1000AKE(-SB)
FM-1000AKE-N(-SB)

A. ICE FLAKER ASSY(1/2)

(A-3) to (E-1)

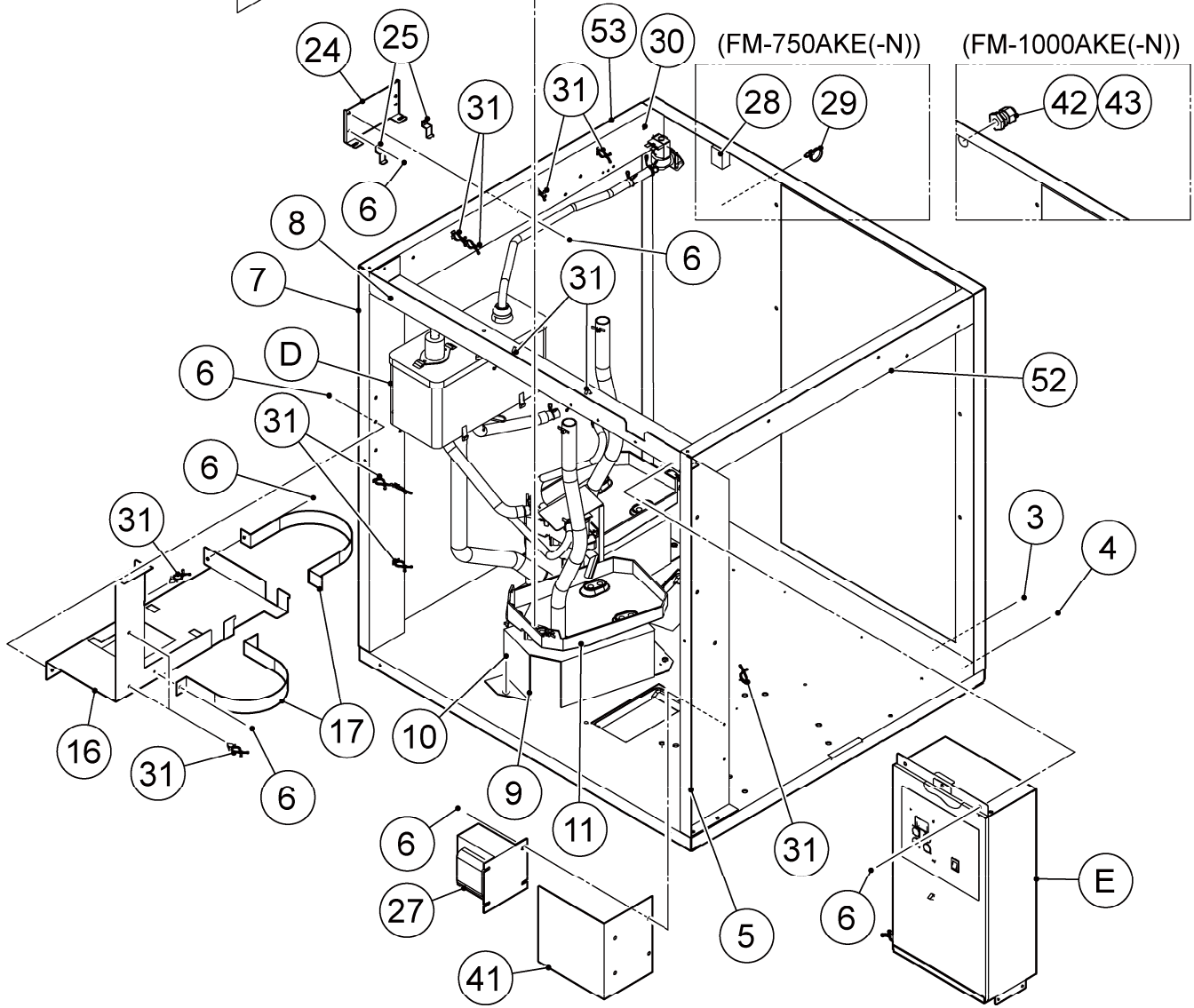
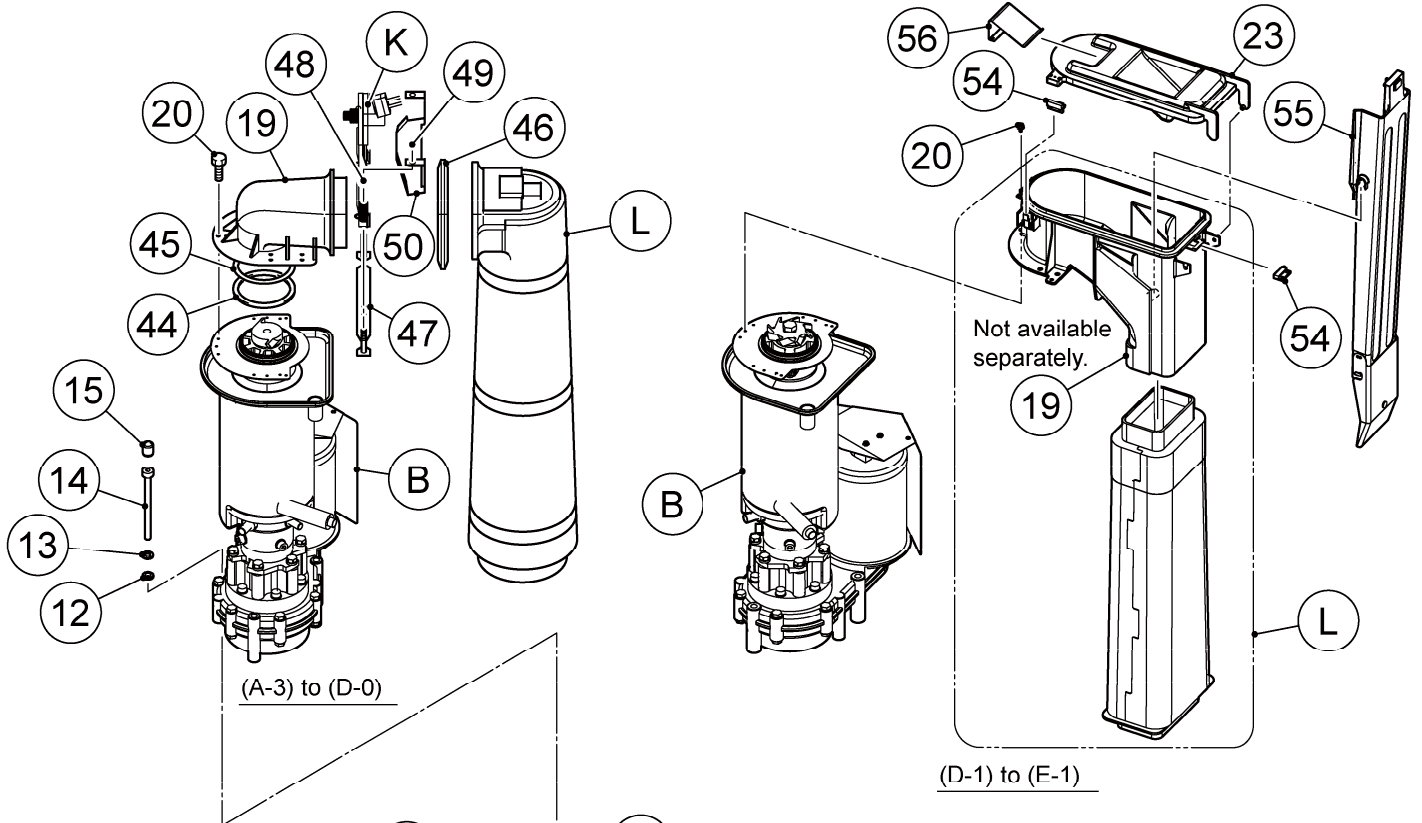

FM-750AKE(-SB)
FM-750AKE-N(-SB)
FM-1000AKE(-SB)
FM-1000AKE-N(-SB)

A. ICE FLAKER ASSY(1/2)

(E-2) and later

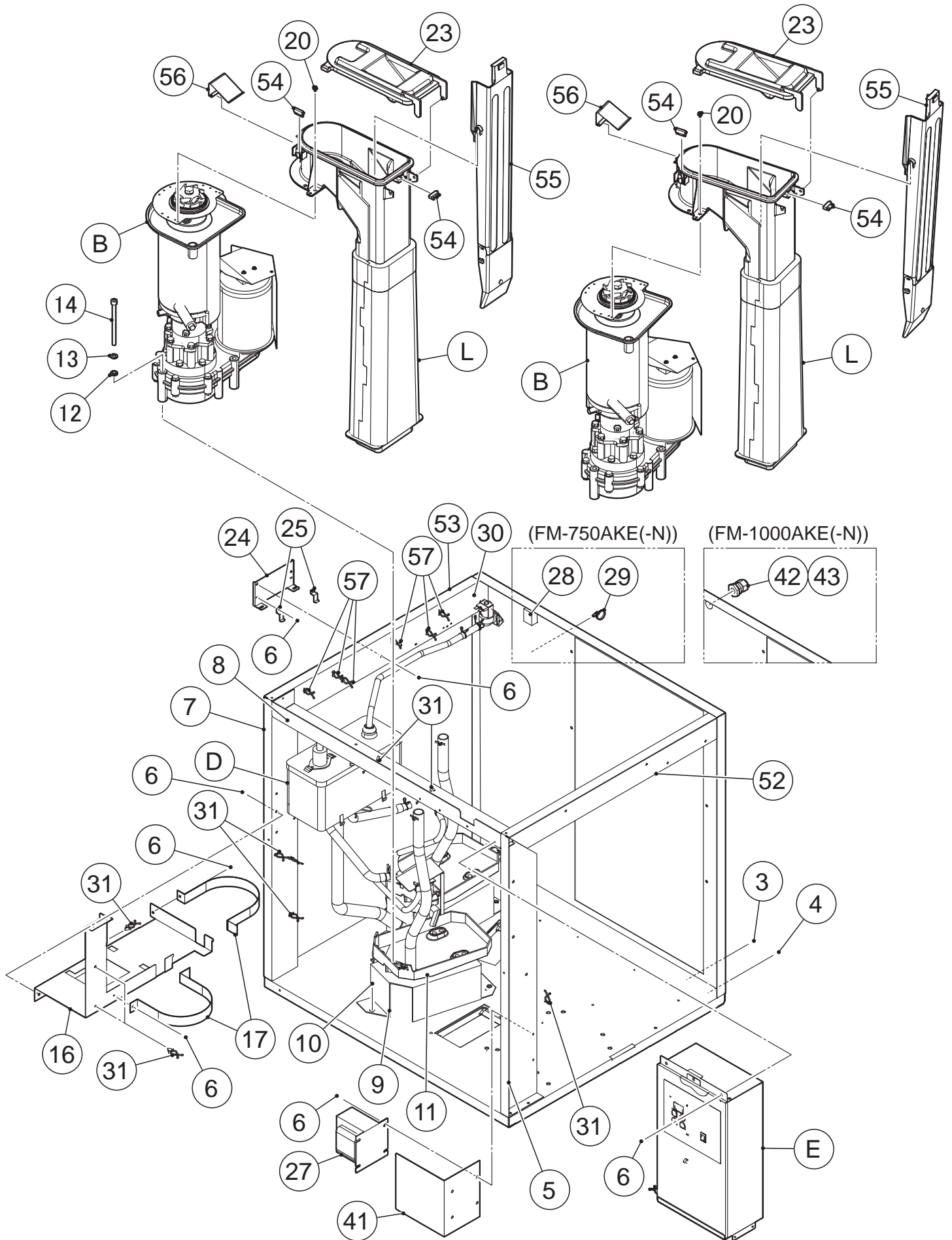

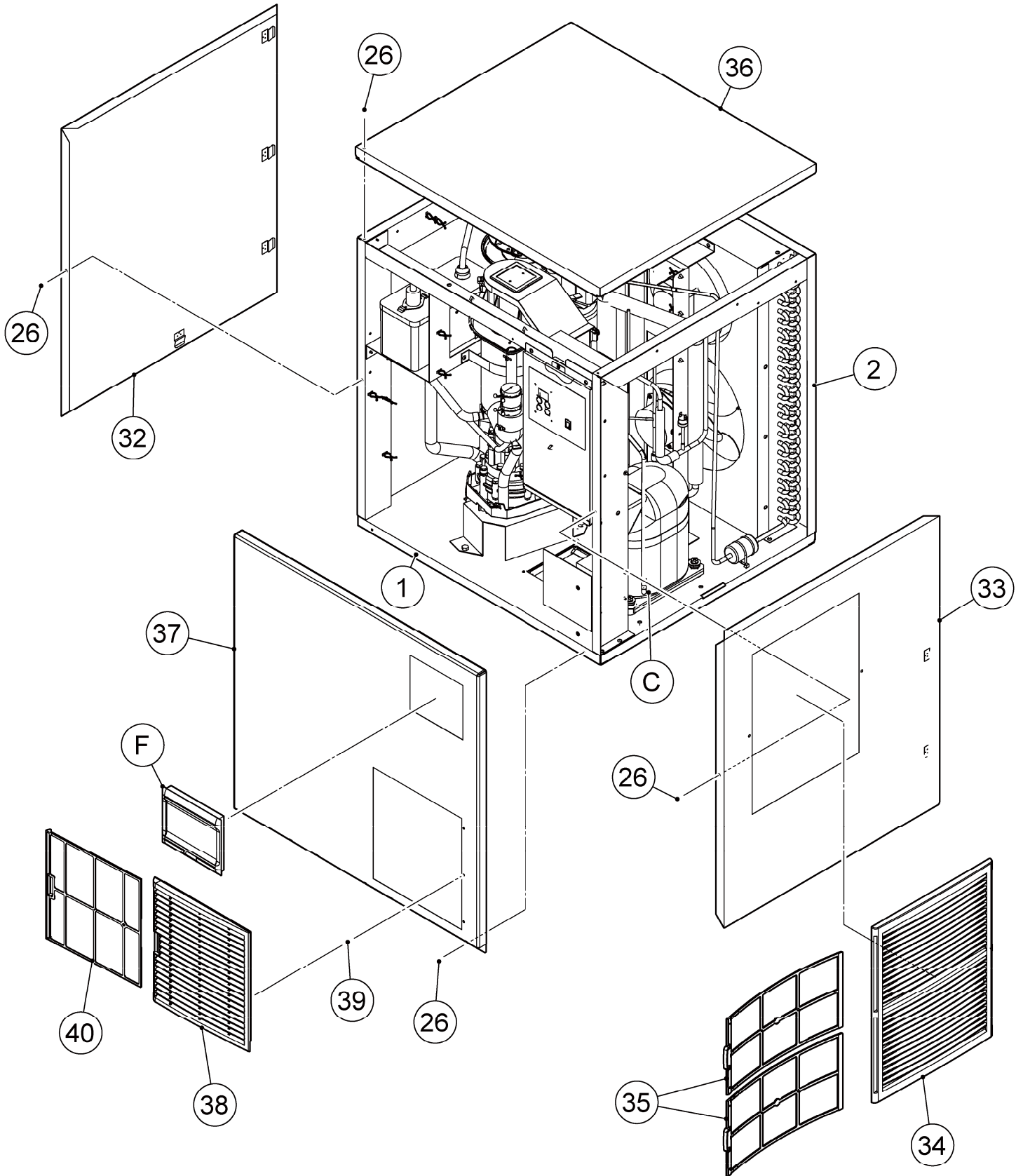

FM-750AKE(-SB)
FM-750AKE-N(-SB)
FM-1000AKE(-SB)
FM-1000AKE-N(-SB)

A. ICE FLAKER ASSY(2/2)

(A-3) and later

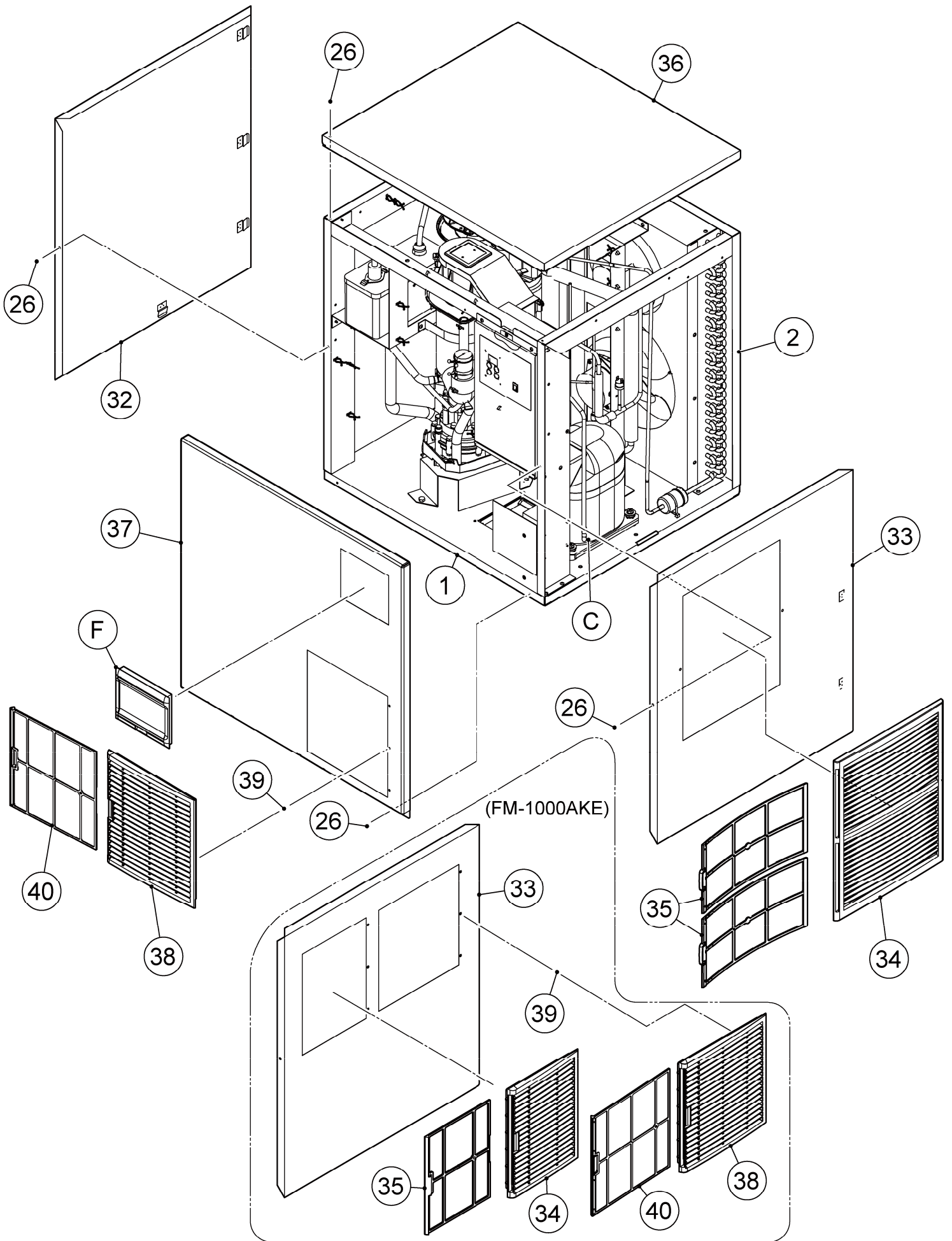

HE

MODEL: FM-750AKE(-SB) FM-750AKE-N(-SB) FM-1000AKE(-SB) FM-1000AKE-N(-SB)								
TITLE: A. ICE FLAKER ASSY								
INDEX NO.	DESCRIPTION	MATERIAL OR MODEL NUMBER	PART NUMBER	REQ'D NUMBER				
				K-1 A-2	A-3 B-0	B-1 D-0	D-1 E-1	E-2
B	ICE MAKING UNIT	(F054, F055)	259147A02	2	-	-	-	-
			259147003	-	2	-	-	-
		(F054)	262649A01	-	-	2	-	-
			264097A03	-	-	-	2	2
		(F054-C101)		-	-	-	2	2
		(F055)	262649A02	-	-	2	-	-
			264097A04	-	-	-	2	2
		(F055-C101)		-	-	-	2	2
		(F054-C106, F055-C106)	259147A03	2	-	-	-	-
			259147004	-	2	-	-	-
			262649A03	-	-	2	-	-
			264097A10	-	-	-	2	2
		(F054-C107, F055-C107)		-	-	-	2	2
		C	REFRIGERATION CIRCUIT	(F054, F054-C106)	120943A01	1	-	-
120943001	-				1	-	-	-
121886A01	-				-	1	-	-
122425A01	-				-	-	1	1
(F054-C101, F054-C107)				-	-	-	1	1
(F055, F055-C106)	120942A01			1	-	-	-	-
	120942001				1	1	-	-
	122426A01			-	-	-	1	1
		-	-	-	1	1		
D	WATER CIRCUIT		120946A01	1	-	-	-	-
			120946001	-	1	1	-	-
			122427A01	-	-	-	1	1
E	CONTROL BOX ASSY	(F054, F054-C106)	259156A02	1	1	-	-	-
			263184A02	-	-	1	1	1
		(F054-C101, F054-C107)		-	-	-	1	1
		(F055, F055-C106)	259156A01	1	1	-	-	-
			263282A01	-	-	1	1	1
(F055-C101, F055-C107)		-	-	-	1	1		

HE

MODEL: FM-750AKE(-SB) FM-750AKE-N(-SB) FM-1000AKE(-SB) FM-1000AKE-N(-SB)								
TITLE: A. ICE FLAKER ASSY								
INDEX NO.	DESCRIPTION	MATERIAL OR MODEL NUMBER	PART NUMBER	REQ'D NUMBER				
				K-1 A-2	A-3 B-0	B-1 D-0	D-1 E-1	E-2
F	WINDOW PANEL ASSY		348243A03	1	1	1	1	1
G	LABEL LOCATION	(F054, F054-C106)	259135A01	1	-	-	-	-
		(F055, F055-C106)	259135A03	1	-	-	-	-
		(F054)	259135001	-	1	-	-	-
			259135006	-	-	1	-	-
			264467A01	-	-	-	1	1
		(F054-C101)	264467001	-	-	-	1	1
		(F054-C106)	259135002	-	1	-	-	-
			259135007	-	-	1	-	-
			264467A02	-	-	-	1	1
		(F054-C107)	264467002	-	-	-	1	1
		(F055)	259135003	-	1	-	-	-
			259135008	-	-	1	-	-
			264467A03	-	-	-	1	1
		(F055-C101)	264467003	-	-	-	1	1
		(F055-C106)	259135004	-	1	-	-	-
			259135009	-	-	1	-	-
264467A04	-		-	-	1	1		
(F055-C107)	264467004	-	-	-	1	1		
J	ACCESSORIES	(F054, F054-C101, F054-C106, F054-C107)	A02525-01	1	1	1	1	1
		(F055, F055-C101, F055-C106, F055-C107)	A02215-01	1	1	1	1	1
K	BAND ASSY	S-9165	348911A01	-	2	2	-	-
L	CHUTE ASSY		113006A01	-	2	2	-	-
		Integrated with 19.SPOUT - 70 Not available separately. Order L.SPOUT ASSY - CHUTE 70 (268065A02)		-	-	-	2	-
	SPOUT ASSY - CHUTE 70		268065A02	-	-	-	-	2
1	CHASSIS		259143G01	1	-	-	-	-
			261345G01	-	1	1	-	-
			264087G01	-	-	-	1	1
		(F054-C101, F054-C107, F055-C101, F055-C107)	266390G01	-	-	-	1	1

HE

MODEL: FM-750AKE(-SB) FM-750AKE-N(-SB) FM-1000AKE(-SB) FM-1000AKE-N(-SB)									
TITLE: A. ICE FLAKER ASSY									
INDEX NO.	DESCRIPTION	MATERIAL OR MODEL NUMBER	PART NUMBER	REQ'D NUMBER					
				K-1 A-2	A-3 B-0	B-1 D-0	D-1 E-1	E-2	
2	REAR PANEL	(F054, F054-C101, F054-C106, F054-C107)	120940M02	1	1	1	1	1	
		(F055, F055-C101, F055-C106, F055-C107)	120940M01	1	1	1	1	1	
3	HEX HEAD BOLT (SPRING WASHER AND FLAT WASHER)	(F054, F054-C101, F054-C106, F054-C107, F055, F055-C101, F055-C107)	FBK0512S0	2	2	2	2	2	
		(F055-C106)		2	4	4	2	2	
4	TRUSS HEAD TAPPING SCREW T2	(F054, F054-C106)	FT20408F0	4	4	4	2	2	
		(F054-C101, F054-C107)		-	-	-	2	2	
		(F055)		4	2	2	2	2	
		(F055-C101, F055-C107)		-	-	-	2	2	
		(F055-C106)		4	-	-	2	2	
5	SIDE FRAME (R1)		264212M01	1	1	1	1	1	
6	TRUSS HEAD MACHINE SCREW		FST0408F0	30	30	24	24	24	
7	SIDE FRAME (L1)		264214M01	1	1	1	1	1	
8	FRONT FRAME		259146M01	1	1	-	-	-	
			262208M01	-	-	1	-	-	
			264081M01	-	-	-	1	1	
9	BRACKET - GEAR MOTOR		374371G01	2	2	2	2	2	
10	HEX HEAD BOLT		FBH0812S0	6	6	6	6	6	
11	DRAIN PAN		323765G01	2	2	-	-	-	
			261640P01	-	-	2	2	2	
12	SEAL WASHER		458299-01	6	6	6	6	6	
13	SPRING WASHER		FWSP08S0	6	6	6	6	6	
14	HEXAGON SOCKET HEAD CAP SCREW		461285-01	6	6	6	6	6	
15	VINYL CAP		451272-01	6	6	6	-	-	
16	BRACKET-RESERVOIR		259148M01	1	-	-	-	-	
			261346M01	-	1	1	-	-	
			264083M01	-	-	-	1	1	
17	BAND		475195M01	2	2	2	2	2	
18	BIN CONTROL		375652G03	2	-	-	-	-	

HE

MODEL: FM-750AKE(-SB) FM-750AKE-N(-SB) FM-1000AKE(-SB) FM-1000AKE-N(-SB)								
TITLE: A. ICE FLAKER ASSY								
INDEX NO.	DESCRIPTION	MATERIAL OR MODEL NUMBER	PART NUMBER	REQ'D NUMBER				
				K-1 A-2	A-3 B-0	B-1 D-0	D-1 E-1	E-2
19	SPOUT - 70		373329G01	2	-	-	-	-
	SPOUT		104797-01	-	2	2	-	-
	SPOUT - 70	Integrated with CHUTE Not available separately. Order SPOUT - CHUTE 70 (268064G02)		-	-	-	2	-
20	HEX HEAD BOLT (SPRING WASHER AND FLAT WASHER)		FBK0408S0	6	6	6	6	6
21	LEAD SWITCH		431788-01	2	-	-	-	-
22	TRUSS HEAD TAPPING SCREW T2		FT20308M0	2	-	-	-	-
23	SPOUT COVER - 70		256359G01	2	-	-	-	-
			263887G01	-	-	-	2	2
24	BRACKET-WATER SUPPLY		475199M01	1	1	-	-	-
			476650M01	-	-	1	1	1
25	BRACKET (A) - WATER SUPPLY		474638M01	2	2	-	-	-
26	TRUSS HEAD MACHINE SCREW		FST0408S0	5	5	13	13	13
27	TRANSFORMER		469405-01	1	1	-	-	-
28	CONNECTOR	(F054, F054-C101, F054-C106, F054-C107)	P00246-01	1	1	1	1	1
29	PUSH MOUNT TIE	(F054, F054-C106)	436156-01	1	1	1	-	-
30	PAN HEAD MACHINE SCREW (SPRING WASHER AND FLAT WASHER)		FSK0408S0	1	1	1	1	1
31	CLAMP	No.249	427902-03	15	15	15	16	10
32	SIDE PANEL(L)		234110G01	1	1	-	-	-
			263237M01	-	-	1	1	1
33	SIDE PANEL (R)	(F054, F054-C106)	258142G01	1	1	-	-	-
			263238M01	-	-	1	1	1
		(F054-C101, F054-C107, F055-C101, F055-C107)		-	-	-	1	1
			258142G01	1	-	-	-	-
		(F055, F055-C106)	261367G01	-	1	-	-	-
			263238M01	-	-	1	1	1

HE

MODEL: FM-750AKE(-SB) FM-750AKE-N(-SB) FM-1000AKE(-SB) FM-1000AKE-N(-SB)								
TITLE: A. ICE FLAKER ASSY								
INDEX NO.	DESCRIPTION	MATERIAL OR MODEL NUMBER	PART NUMBER	REQ'D NUMBER				
				K-1 A-2	A-3 B-0	B-1 D-0	D-1 E-1	E-2
34	LOUVER	(F054, F054-C106)	1A1329-01	1	1	-	-	-
			121931P01	-	-	3	3	3
		(F054-C101, F054-C107, F055-C101, F055-C107)		-	-	-	3	3
			(F055, F055-C106)	1A1329-01	1	-	-	-
		1A0548-01	-	1	-	-	-	
		121931P01	-	-	3	3	3	
35	AIR FILTER	(F054, F054-C106)	2A4128G01	2	2	-	-	-
			262259G01	-	-	3	3	3
		(F054-C101, F054-C107, F055-C101, F055-C107)		-	-	-	3	3
			(F055, F055-C106)	2A4128G01	2	-	-	-
		2A2063G01	-	1	-	-	-	
		262259G01	-	-	3	3	3	
36	TOP PANEL		259153M01	1	1	1	1	1
37	FRONT PANEL (A)		120949M01	1	1	-	-	-
			122242G01	-	-	1	1	1
38	LOUVER A	(F054, F054-C106)	1A0547-01	1	1	-	-	-
		(F055)		1	2	-	-	-
		(F055-C106)		1	1	-	-	-
39	PUSH RETAINER	(F054, F054-C106)	4A2414-01	3	3	-	-	-
		(F055)		3	9	-	-	-
		(F055-C106)		3	3	-	-	-
40	AIR FILTER A	(F054, F054-C106)	2A2062G01	1	1	-	-	-
		(F055)		1	2	-	-	-
		(F055-C106)		1	1	-	-	-
41	COVER - TRANSFORMER		475235M01	1	1	-	-	-
42	PERFECT LOCK	(F055, F055-C101, F055-C106, F055-C107)	466342-01	1	1	1	1	1
43	POWER SUPPLY CORD	(F055, F055-C101, F055-C106, F055-C107)	466418-01	1	1	1	1	1
44	RING		432661-02	-	2	2	-	-
45	O-RING	4DG70	7616-G070	-	2	2	-	-
46	PACKING		454256-01	-	2	2	-	-

HE

MODEL: FM-750AKE(-SB) FM-750AKE-N(-SB) FM-1000AKE(-SB) FM-1000AKE-N(-SB)								
TITLE: A. ICE FLAKER ASSY								
INDEX NO.	DESCRIPTION	MATERIAL OR MODEL NUMBER	PART NUMBER	REQ'D NUMBER				
				K-1 A-2	A-3 B-0	B-1 D-0	D-1 E-1	E-2
47	BAND (B)		459995G01	-	2	2	-	-
48	FLANGE NUT		FNHF06S0	-	6	6	-	-
49	NUT		FNH106S0	-	10	10	-	-
50	DRIP GUIDE		350725-01	-	2	2	-	-
51	CLAMP		428644-03	-	-	2	2	2
52	SIDE FRAME (R2)		264213M01	1	1	1	1	1
53	SIDE FRAME (L2)		264215M01	1	1	1	1	1
54	REED SWITCH		P02940-01	-	-	-	4	4
55	ACTUATOR	(F054, F054-C101, F055, F055-C101)	382184G02	-	-	-	2	2
		(F054-C106, F054-C107, F055-C106, F055-C107)	382184G01	-	-	-	2	2
56	SPRING - SPOUT		478013M01	-	-	-	2	2
57	CLAMP	No.2674	427902-02	-	-	-	-	6

FM-750AKE(-SB)
 FM-750AKE-N(-SB)
 FM-1000AKE(-SB)
 FM-1000AKE-N(-SB)

B. ICE MAKING UNIT

(K-1) and later

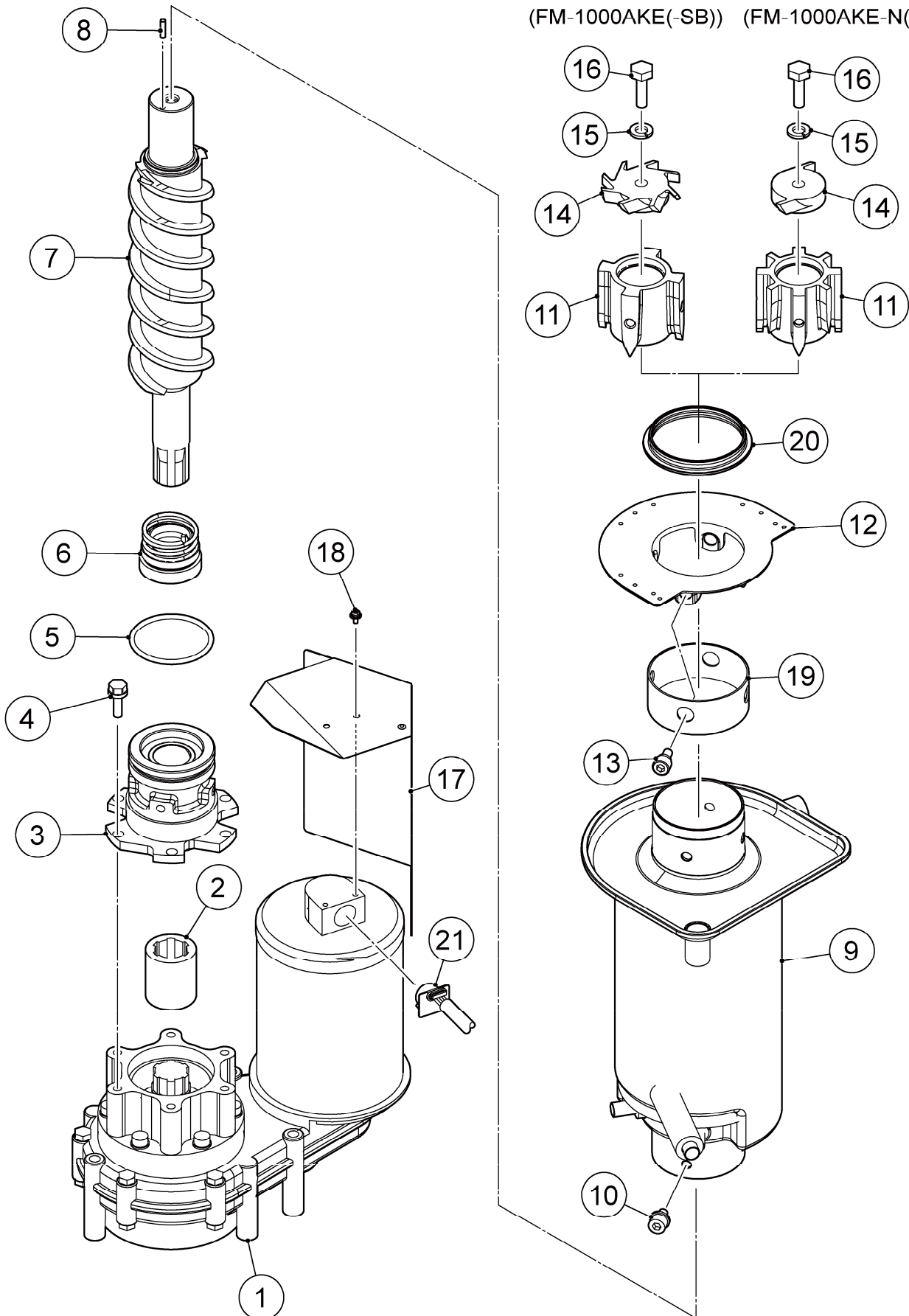

HE

MODEL: FM-750AKE(-SB) FM-750AKE-N(-SB) FM-1000AKE(-SB) FM-1000AKE-N(-SB)								
TITLE: B. ICE MAKING UNIT								
INDEX NO.	DESCRIPTION	MATERIAL OR MODEL NUMBER	PART NUMBER	REQ'D NUMBER				
				K-1 A-2	A-3 B-0	B-1 D-0	D-1 E-1	E-2
1	GEAR MOTOR		466223-01	1	1	1	1	1
2	COUPLING		414137-01	1	1	1	1	1
3	HOUSING		206657G02	1	1	1	1	1
4	HEX.HEAD BOLT W/WASHER (SW)		461888-01	6	6	6	6	6
5	O-RING		7616-G065	1	1	1	1	1
6	MECHANICAL SEAL		432492-01	1	1	1	1	1
7	AUGER		120863G02	1	1	1	1	1
8	PIN		713S-0416	1	1	1	1	1
9	EVAPORATOR		258997G01	1	1	1	1	1
10	SCREW		P01719-01	4	4	4	4	4
11	EXTRUDING HEAD	(F054, F055)	327097G02	1	1	-	-	-
			327097G04	-	-	1	1	1
		(F054-C101, F055-C101)		-	-	-	1	1
		(F054-C106, F054-C107, F055-C106, F055-C107)	216531G02	1	1	1	1	1
12	FLANGE - 70		372207M01	1	-	-	-	-
			476246G01	-	1	1	-	-
			372207M01	-	-	-	1	1
13	SEAL BOLT - M8		P01768-01	4	4	4	4	4
14	CUTTER	(F054, F054-C101, F055, F055-C101)	317071-02	1	1	1	1	1
		(F054-C106, F054-C107, F055-C106, F055-C107)	327145-01	1	1	1	1	1
15	SPRING WASHER		FWSP10S0	1	1	1	1	1
16	SCREW-BOLT		458101-01	1	1	1	1	1
17	COVER-GEAR MOTOR		475224G01	1	1	1	1	1
18	PAN HEAD MACHINE SCREW (SPRING WASHER AND FLAT WASHER)		FSK0408S0	2	2	2	2	2
19	BELT HEATER		469322-01	1	1	-	-	-
		(F054-C106, F054-C107, F055, F055-C101, F055-C106, F055-C107)	P03243-01	-	-	1	1	1

HE

MODEL: FM-750AKE(-SB) FM-750AKE-N(-SB) FM-1000AKE(-SB) FM-1000AKE-N(-SB)									
TITLE: B. ICE MAKING UNIT									
INDEX NO.	DESCRIPTION	MATERIAL OR MODEL NUMBER	PART NUMBER	REQ'D NUMBER					
				K-1 A-2	A-3 B-0	B-1 D-0	D-1 E-1	E-2	
20	PACKING - SPOUT		473494R01	1	1	-	1	1	
21	ROTATION SENSOR	GEAR MOTOR ACCESSORY	459861-03	1	1	1	1	1	

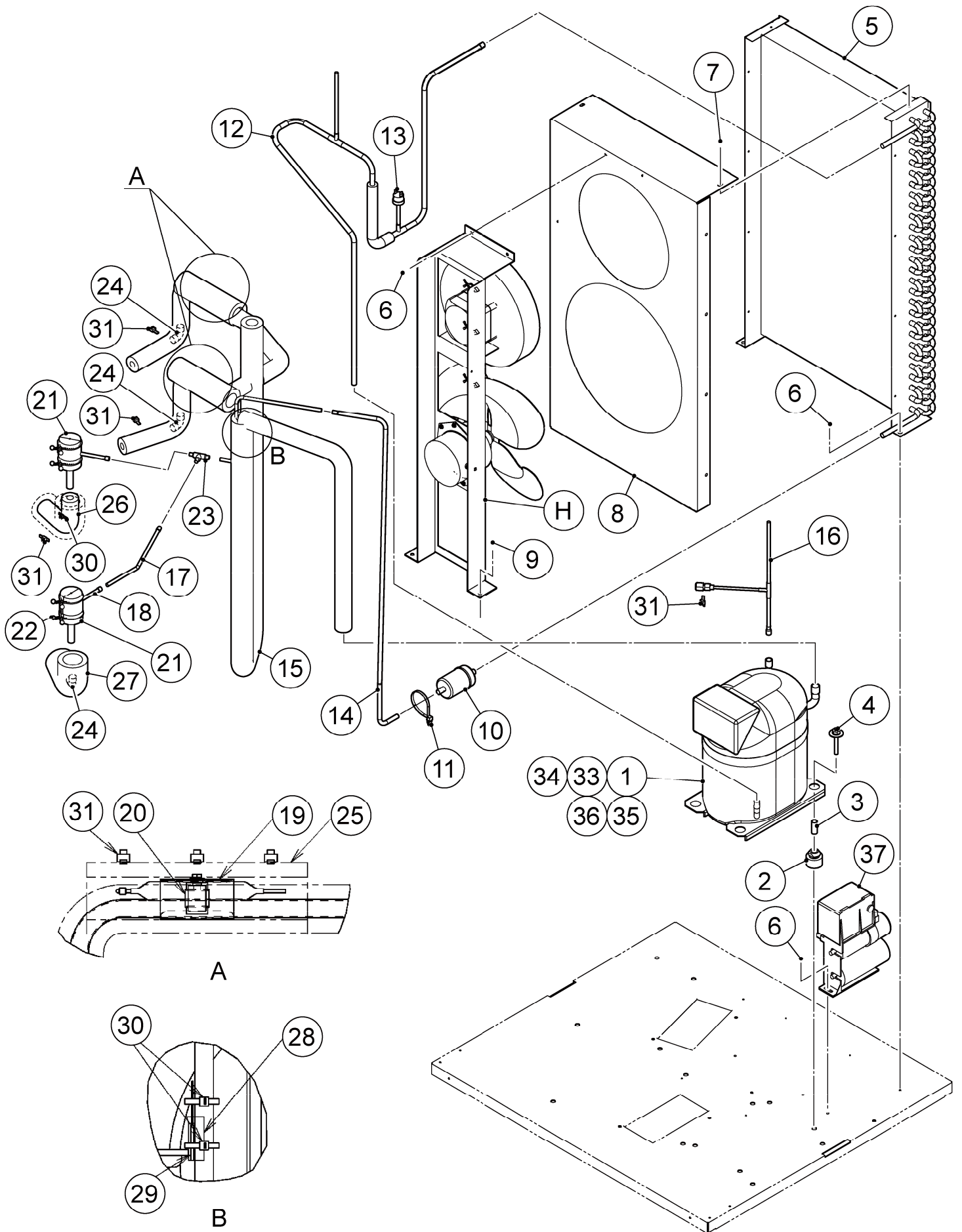

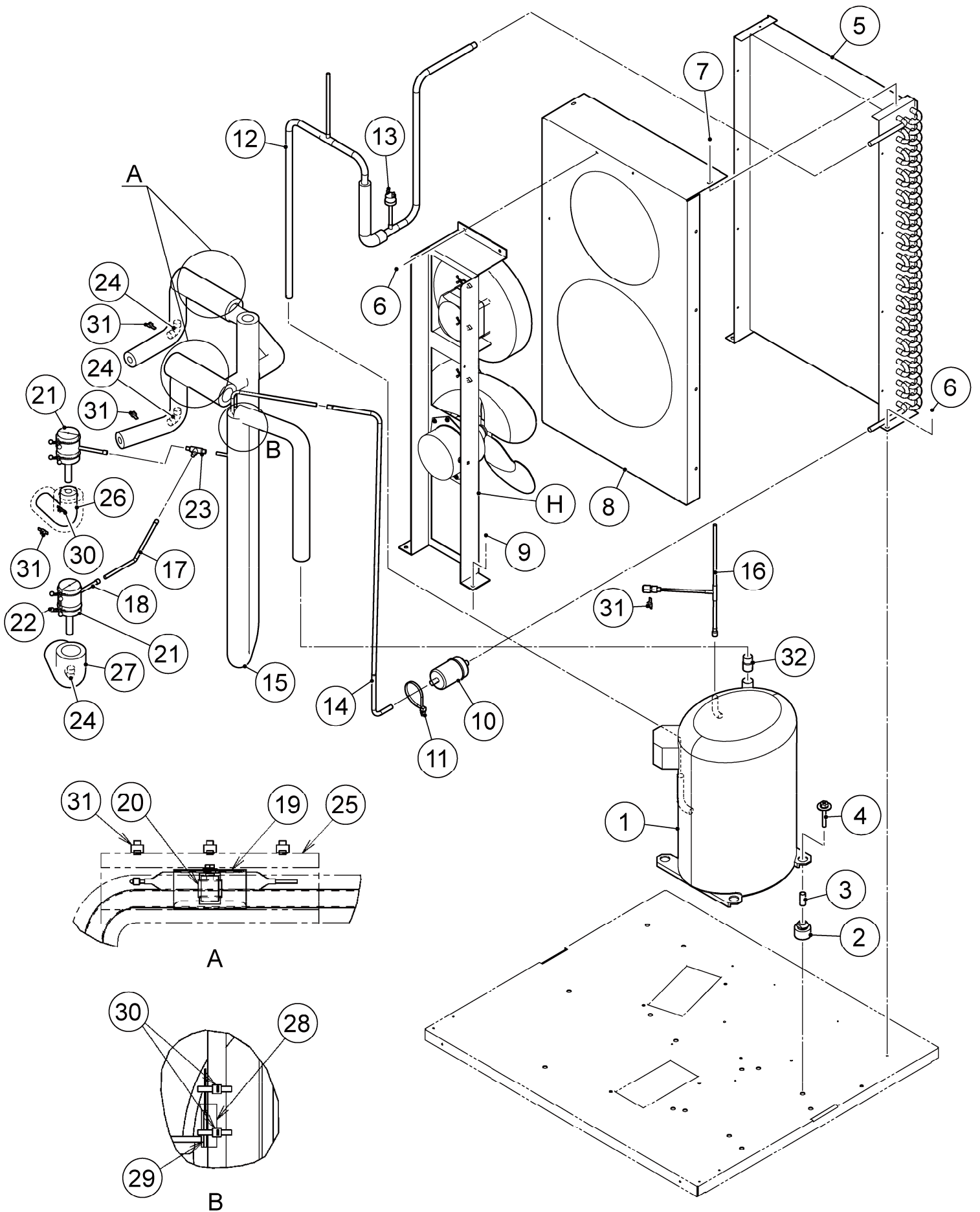

HE

MODEL: FM-750AKE(-SB) FM-750AKE-N(-SB) FM-1000AKE(-SB) FM-1000AKE-N(-SB)								
TITLE: C. REFRIGERATION CIRCUIT								
INDEX NO.	DESCRIPTION	MATERIAL OR MODEL NUMBER	PART NUMBER	REQ'D NUMBER				
				K-1 A-2	A-3 B-0	B-1 D-0	D-1 E-1	E-2
H	FAN MOTOR ASSY		241617A01	1	1	-	-	-
			262065A01	-	-	1	1	1
1	COMPRESSOR	(F054, F054-C106)	4A1581-01	1	1	-	-	-
			P02532-01	-	-	1	1	1
		(F054-C101, F054-C107)		-	-	-	1	1
				-	-	-	1	1
		(F055, F055-C106)	466224-01	1	1	-	-	-
			P02588-01	-	-	1	1	1
(F055-C101, F055-C107)		-	-	-	1	1		
		-	-	-	1	1		
2	GROMMET	(F054, F054-C106)	434922-02	4	4	-	-	-
			P00846-01	-	-	4	4	4
		(F054-C101, F054-C107)		-	-	-	4	4
				-	-	-	4	4
(F055, F055-C101, F055-C106, F055-C107)	434922-02	4	4	4	4	4		
		4	4	4	4	4		
3	SPACER	(F054, F054-C106)	434921-01	4	4	-	-	-
			P00847-01	-	-	4	4	4
		(F054-C101, F054-C107)		-	-	-	4	4
				-	-	-	4	4
(F055, F055-C101, F055-C106, F055-C107)	434921-01	4	4	4	4	4		
		4	4	4	4	4		
4	BOLT		436206-04	4	4	4	4	4
5	CONDENSER-AIR COOLED		P03407-01	1	1	1	1	1
6	TRUSS HEAD MACHINE SCREW	(F054, F054-C106)	FST0408F0	4	4	6	6	6
				-	-	-	6	6
		(F054-C101, F054-C107)		-	-	-	6	6
(F055, F055-C101, F055-C106, F055-C107)		4	4	4	4	4		
		4	4	4	4	4		
7	TRUSS HEAD TAPPING SCREW T2		FT20408F0	16	16	16	16	16
8	SHROUD		114398-01	1	-	-	-	-
			121539M01	-	1	-	-	-
			121787M01	-	-	1	1	1
9	HEX HEAD BOLT (SPRING WASHER AND FLAT WASHER)		FBK0512S0	2	2	2	2	2
10	DRIER		462965-01	1	1	1	1	1
11	TIE		436156-02	1	1	1	1	1

HE

MODEL: FM-750AKE(-SB) FM-750AKE-N(-SB) FM-1000AKE(-SB) FM-1000AKE-N(-SB)								
TITLE: C. REFRIGERATION CIRCUIT								
INDEX NO.	DESCRIPTION	MATERIAL OR MODEL NUMBER	PART NUMBER	REQ'D NUMBER				
				K-1 A-2	A-3 B-0	B-1 D-0	D-1 E-1	E-2
12	COPPER TUBE(A) - H	(F054, F054-C106)	259151G01	1	1	-	-	-
			262187G01	-	-	1	1	1
		(F054-C101, F054-C107)		-	-	-	1	1
		(F055, F055-C106)	259149G01	1	-	-	-	-
			261342G01	-	1	1	1	1
(F055-C101, F055-C107)		-	-	-	1	1		
13	PRESSURE SWITCH	R134a,R22,R404A COPPER TUBE A/H	459863-06	1	1	1	1	1
14	COPPER TUBE(B) - H		374373M01	1	1	1	1	1
15	COPPER TUBE(L)	(F054, F054-C106)	120945G01	1	-	-	-	-
			121536G01	-	1	-	-	-
			121881G01	-	-	1	-	-
			122419G01	-	-	-	1	1
		(F054-C101, F054-C107)						
		(F055, F055-C106)	120944G01	1	-	-	-	-
			121534G01	-	1	1	1	1
			122420G01	-	-	-	1	1
(F055-C101, F055-C107)								
16	COPPER TUBE-ACCESS VALVE	(F054, F054-C106)	466222G01	1	1	-	-	-
			476690G01	-	-	1	1	1
		(F054-C101, F054-C107)		-	-	-	1	1
		(F055, F055-C101, F055-C106, F055-C107)	466222G01	1	1	1	1	1
17	COPPER TUBE(E)/H		475197M01	1	-	-	-	-
			476240M01	-	1	1	-	-
			478300M01	-	-	-	1	1
18	EXPANSION VALVE		453868-01	2	2	2	2	2
19	HOLDER - EXP. VALVE 1/2		3A0112-01	2	2	2	2	2
20	CLAMP		443461-01	2	2	2	2	2
21	VALVE COVER		3Y3196P01	2	2	2	2	2
22	CLAMP		P00752-01	4	4	4	4	4
23	TEE		4R3125-01	1	1	1	1	1
24	ELBOW		417395-03	4	4	4	4	4

HE

MODEL: FM-750AKE(-SB) FM-750AKE-N(-SB) FM-1000AKE(-SB) FM-1000AKE-N(-SB)								
TITLE: C. REFRIGERATION CIRCUIT								
INDEX NO.	DESCRIPTION	MATERIAL OR MODEL NUMBER	PART NUMBER	REQ'D NUMBER				
				K-1 A-2	A-3 B-0	B-1 D-0	D-1 E-1	E-2
25	INSULATION TUBE		H72949B15	2	2	2	2	2
26	INSULATION TUBE		H71333B35	2	2	2	2	2
27	INSULATION TUBE		H73858B28	2	2	2	2	2
28	HOLDER - THERMISTOR	(F054, F054-C101, F054-C106, F054-C107)	427430-01	1	1	1	1	1
		(F055, F055-C101, F055-C106, F055-C107)	438247-01	1	1	1	1	1
29	THERMISTOR ASSY		475407G01	1	1	1	1	1
30	TIE	CV-150	7920-0003	6	6	6	6	6
31	TIE	(F054, F054-C106)	7920-0010	14	14	15	15	15
		(F055, F055-C106)		14	14	14	15	15
		(F054-C101, F054-C107, F055-C101, F055-C107)		-	-	-	15	15
32	REDUCER	(F055, F055-C106)	420915-12	1	1	-	-	-
33	PROTECTOR	(F054, F054-C106)	4A1877-04	1	1	-	-	-
			P02534-01	-	-	1	1	1
		(F054-C101, F054-C107)		-	-	-	1	1
34	LOCKRING STOPPER		P01677-01	-	-	1	1	1
35	CARTON PACKING	(F054, F054-C101, F054-C106, F054-C107)	P02535-01	-	-	1	1	1
36	METRIC SCREW	(F054, F054-C101, F054-C106, F054-C107)	P02657-01	-	-	1	1	1
37	TERMINAL COVER	(F054, F054-C101, F054-C106, F054-C107)	P02536-01	-	-	1	1	1
38	BOX WITH ELECTRICAL COMPONE	(F054, F054-C101, F054-C106, F054-C107)	P02533-01	-	-	1	1	1
39	CRANKCASE HEATER	(F055, F055-C101, F055-C106, F055-C107)	4A5397-01	-	-	1	1	1
40	TERMINAL COVER	(F055, F055-C101, F055-C106, F055-C107)	P02823-01	-	-	1	1	1

FM-750AKE(-SB)
FM-750AKE-N(-SB)
FM-1000AKE(-SB)
FM-1000AKE-N(-SB)

D. WATER CIRCUIT

(K-1) and later

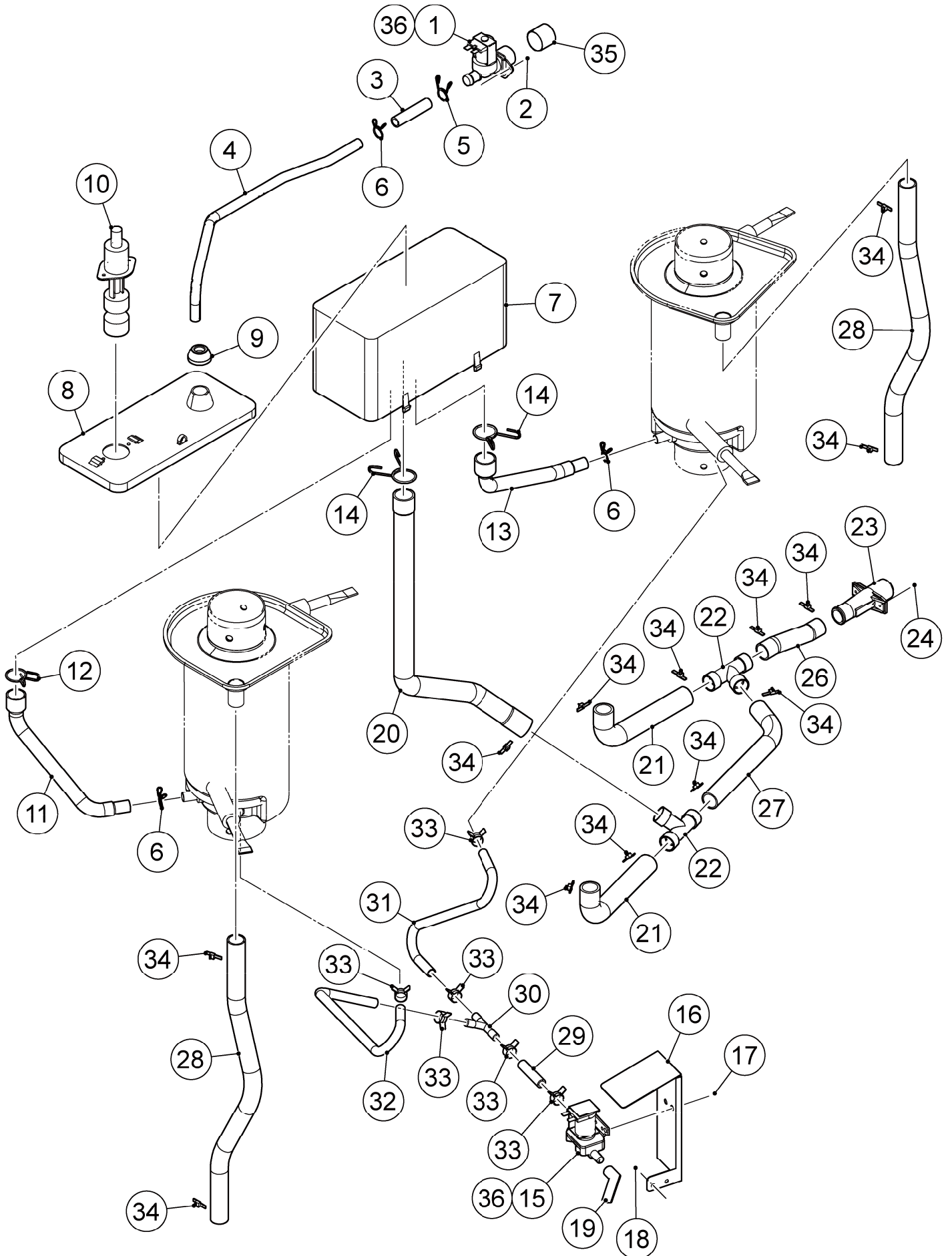

HE

MODEL: FM-750AKE(-SB) FM-750AKE-N(-SB) FM-1000AKE(-SB) FM-1000AKE-N(-SB)								
TITLE: D. WATER CIRCUIT								
INDEX NO.	DESCRIPTION	MATERIAL OR MODEL NUMBER	PART NUMBER	REQ'D NUMBER				
				K-1 A-2	A-3 B-0	B-1 D-0	D-1 E-1	E-2
1	WATER VALVE		452993-01	1	1	1	1	1
2	HEX HEAD BOLT		FBH0408S0	2	2	2	2	2
3	SILICONE HOSE		4Y6912R06	1	1	1	1	1
4	PIPE-WATER SUPPLY		374379M01	1	-	-	-	-
			375950M01	-	1	1	-	-
			374379M01	-	-	-	1	1
5	HOSE CLAMP		435934-03	1	1	1	1	1
6	HOSE CLAMP		435934-02	3	3	3	3	3
7	RESERVOIR(B)		114487-01	1	1	1	1	1
8	RESERVOIR COVER		112582-01	1	1	1	1	1
9	COVER - RESERVOIR INLET		415094-01	1	1	1	1	1
10	FLOAT SWITCH		458279-01	1	1	1	1	1
11	HOSE (A)		374346R01	1	1	1	1	1
12	HOSE CLAMP		427443-10	1	1	1	1	1
13	HOSE (B)		374347R01	1	1	1	1	1
14	HOSE CLAMP		427443-08	2	2	2	2	2
15	WATER VALVE		468655-01	1	1	1	1	1
16	VALVE BRACKET		461831-01	1	1	1	1	1
17	HEX HEAD BOLT (SPRING WASHER AND FLAT WASHER)		FBK0508F0	2	2	2	2	2
18	PAN HEAD MACHINE SCREW (SPRING WASHER AND FLAT WASHER)		FSK0408F0	2	2	2	2	2
19	DRAIN PIPE		460263-01	1	1	1	1	1
20	HOSE(B)		360004-01	1	1	1	1	1
21	HOSE(C)		475198G01	2	2	2	2	2
22	TEE		364488-01	2	2	2	2	2
23	DRAIN PIPE		321035-01	1	1	1	1	1
24	TRUSS HEAD TAPPING SCREW T2		FT20410S0	2	2	2	2	2
26	PVC HOSE (FOOD GRADE)		HD1923120	1	-	-	-	-
			HD1923080	-	1	1	-	-
			HD1923120	-	-	-	1	1
27	PVC HOSE (FOOD GRADE)		HD1923250	1	-	-	-	-
			HD1923270	-	1	1	1	1
28	PVC HOSE (FOOD GRADE)		HD1923460	2	2	2	2	2

HE

MODEL: FM-750AKE(-SB) FM-750AKE-N(-SB) FM-1000AKE(-SB) FM-1000AKE-N(-SB)								
TITLE: D. WATER CIRCUIT								
INDEX NO.	DESCRIPTION	MATERIAL OR MODEL NUMBER	PART NUMBER	REQ'D NUMBER				
				K-1 A-2	A-3 B-0	B-1 D-0	D-1 E-1	E-2
29	PVC HOSE (FOOD GRADE)		HD0912050	1	1	1	1	1
30	JOINT		450297-04	1	1	1	1	1
31	PVC HOSE (FOOD GRADE)		HD0912400	1	1	1	1	1
32	PVC HOSE (FOOD GRADE)		HD0912500	1	1	1	1	1
33	CLAMP		423866-03	6	6	6	6	6
34	TIE	CV-150	7920-0003	13	13	13	13	13
35	CAP		417323-01	1	1	1	1	1
36	NOISE KILLER		450363-01	-	2	2	2	2

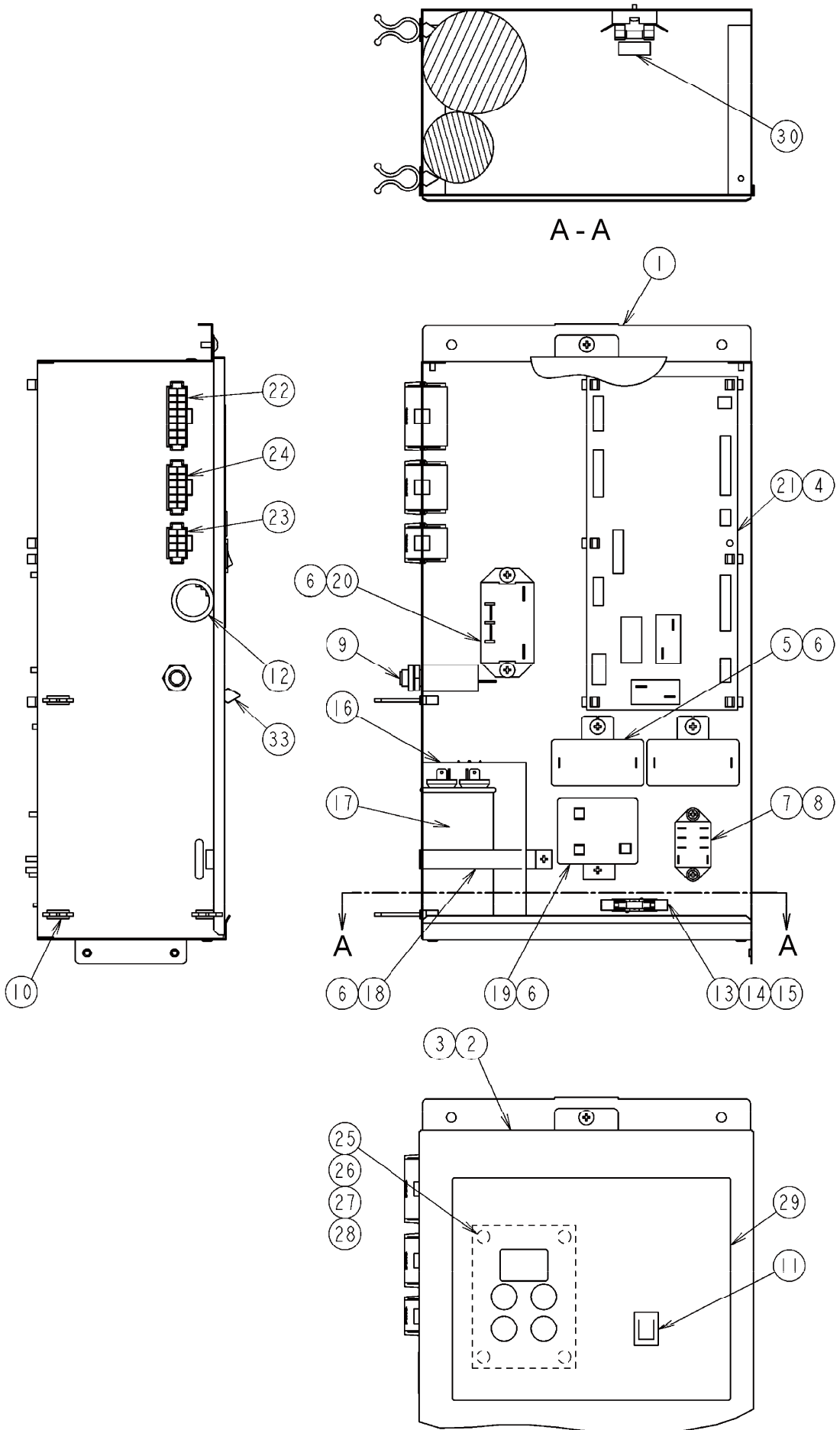

FM-750AKE(-SB)
FM-750AKE-N(-SB)
FM-1000AKE(-SB)
FM-1000AKE-N(-SB)

E. CONTROL BOX ASSY

(B-1) and later

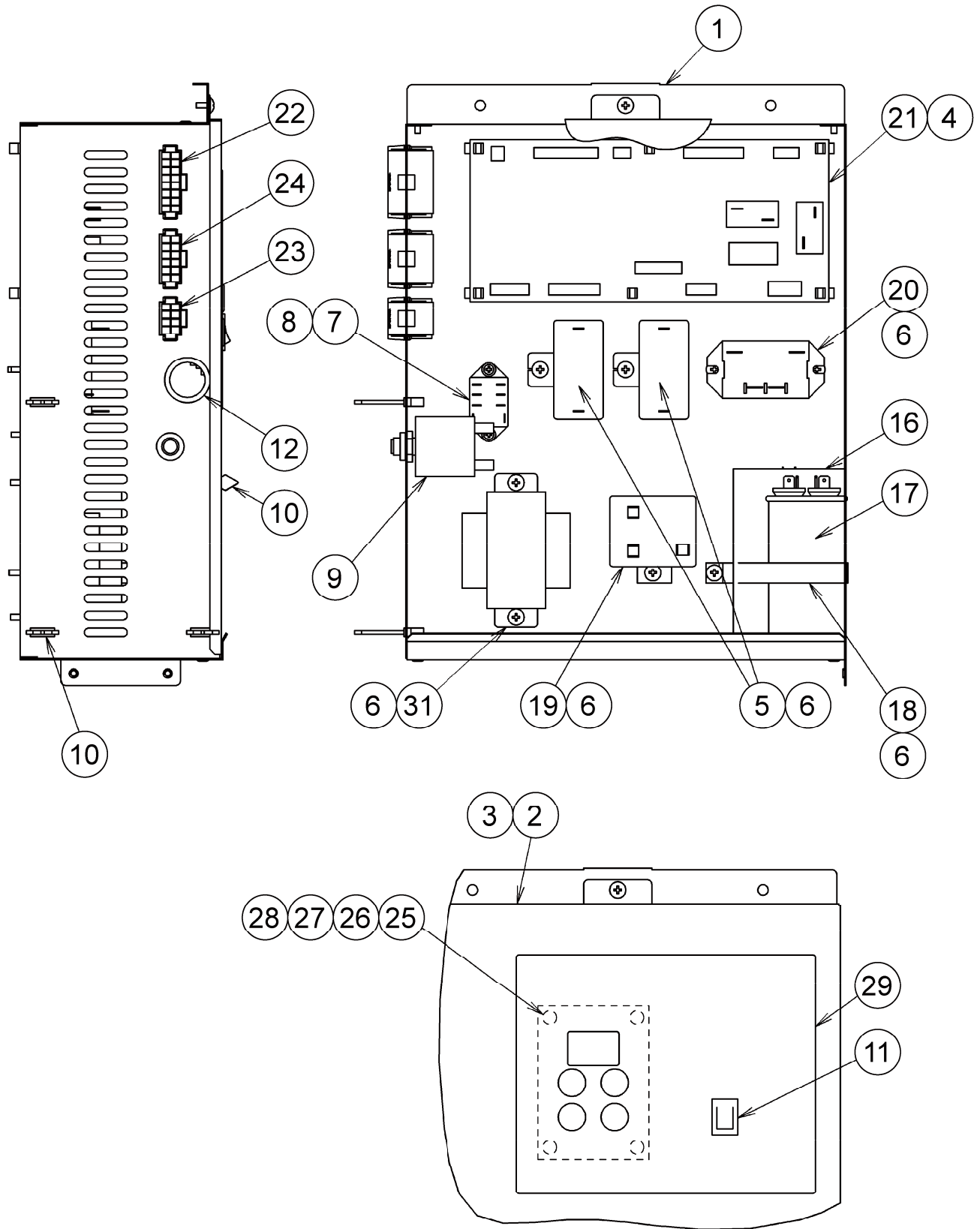

HE

MODEL: FM-750AKE(-SB) FM-750AKE-N(-SB) FM-1000AKE(-SB) FM-1000AKE-N(-SB)								
TITLE: E. CONTROL BOX ASSY								
INDEX NO.	DESCRIPTION	MATERIAL OR MODEL NUMBER	PART NUMBER	REQ'D NUMBER				
				K-1 A-2	A-3 B-0	B-1 D-0	D-1 E-1	E-2
1	CONTROL BOX		120948G01	1	1	-	-	-
		(F054, F054-C101, F054-C106, F054-C107)	121824G01	-	-	1	1	1
		(F055, F055-C101, F055-C106, F055-C107)	122174G01	-	-	1	1	1
2	COVER - CONTROL BOX		374380G01	1	1	-	-	-
			376330G01	-	-	1	1	1
3	TRUSS HEAD MACHINE SCREW		FST0408F0	1	1	1	1	1
4	BOARD SUPPORT		414929-01	6	6	6	6	6
5	CAPACITOR		459704-01	2	2	2	2	2
6	TRUSS HEAD TAPPING SCREW T2	(F054, F054-C101, F054-C106, F054-C107)	FT20408F0	4	4	4	4	4
		(F055, F055-C101, F055-C106, F055-C107)	FT20408F0	6	6	10	10	10
7	RELAY		406132-08	1	1	1	1	1
8	TAPPING SCREW		431415-01	2	2	2	2	2
9	CIRCUIT PROTECTOR	(F054, F054-C106)	425201-05	1	1	-	-	-
		(F055, F055-C101, F055-C106, F055-C107)	425201-03	1	1	1	1	1
10	CLAMP	(No.249)	427902-03	4	4	4	4	4
11	ROCKER SWITCH		460681-01	1	1	1	1	1
12	BUSHING		428394-05	1	1	1	1	1
13	FUSE HOLDER		4Y2547-01	1	1	1	1	1
14	FUSE		451924-02	1	1	1	1	1
15	PAN HEAD TAPPING SCREW T2		FT50308F0	1	1	1	1	1
16	START CAPACITOR	(F054, F054-C106)	3A0076-14	1	1	-	-	-
		(F055, F055-C106)	3A0076-18	1	1	-	-	-
17	CAPACITOR	(F054, F054-C106)	4A1631-01	1	1	-	-	-
		(F055, F055-C106)	3A2005-13	1	1	-	-	-
18	STRAP	(F054, F054-C106)	434174-04	1	1	-	-	-
		(F055, F055-C106)	434174-02	1	1	-	-	-
19	STARTER	(F054, F054-C106)	4A1107-02	1	1	-	-	-
		(F055, F055-C106)	4A1107-13	1	1	-	-	-

HE

MODEL: FM-750AKE(-SB) FM-750AKE-N(-SB) FM-1000AKE(-SB) FM-1000AKE-N(-SB)									
TITLE: E. CONTROL BOX ASSY									
INDEX NO.	DESCRIPTION	MATERIAL OR MODEL NUMBER	PART NUMBER	REQ'D NUMBER					
				K-1 A-2	A-3 B-0	B-1 D-0	D-1 E-1	E-2	
20	POWER RELAY	(F055, F055-C106)	449000-01	1	1	-	-	-	
		(F055-C101, F055-C107)	P00034-01	-	-	1	1	1	
				-	-	-	1	1	
21	CONTROLLER BOARD -09CM		P01372-99	1	1	1	1	1	
22	HARNESS (A)		374365G01	1	1	-	-	-	
			376352G01	-	-	1	1	1	
23	HARNESS (B)		473845G01	1	1	1	1	1	
24	HARNESS (C)		374366G01	1	1	1	1	1	
25	SPACER		451658-05	4	4	4	4	4	
26	OPERATION BOARD -09CM		P01373-01	1	1	1	1	1	
27	FLAT WASHER		FWPL03P0	4	4	4	4	4	
28	NUT		FNH103F0	4	4	4	4	4	
29	CONTROL LABEL		374148L01	1	1	1	1	1	
30	LABEL - FUSE		455750-02	1	1	-	-	-	
			477494L01	-	-	1	1	1	
31	TRANSFORMER		P02623-01	-	-	1	1	1	
32	PROTECTOR	(F054, F054-C101, F054-C106, F054-C107)	440972-07	-	-	1	1	1	
33	SEPARATOR/BOX	(F055, F055-C101, F055-C106, F055-C107)	377045M01	-	-	1	1	1	
34	GROMMET	(F055, F055-C101, F055-C106, F055-C107)	4H2568-01	-	-	2	2	2	

FM-750AKE(-SB)
FM-750AKE-N(-SB)
FM-1000AKE(-SB)
FM-1000AKE-N(-SB)

F. WINDOW PANEL ASSY

(K-1) and later

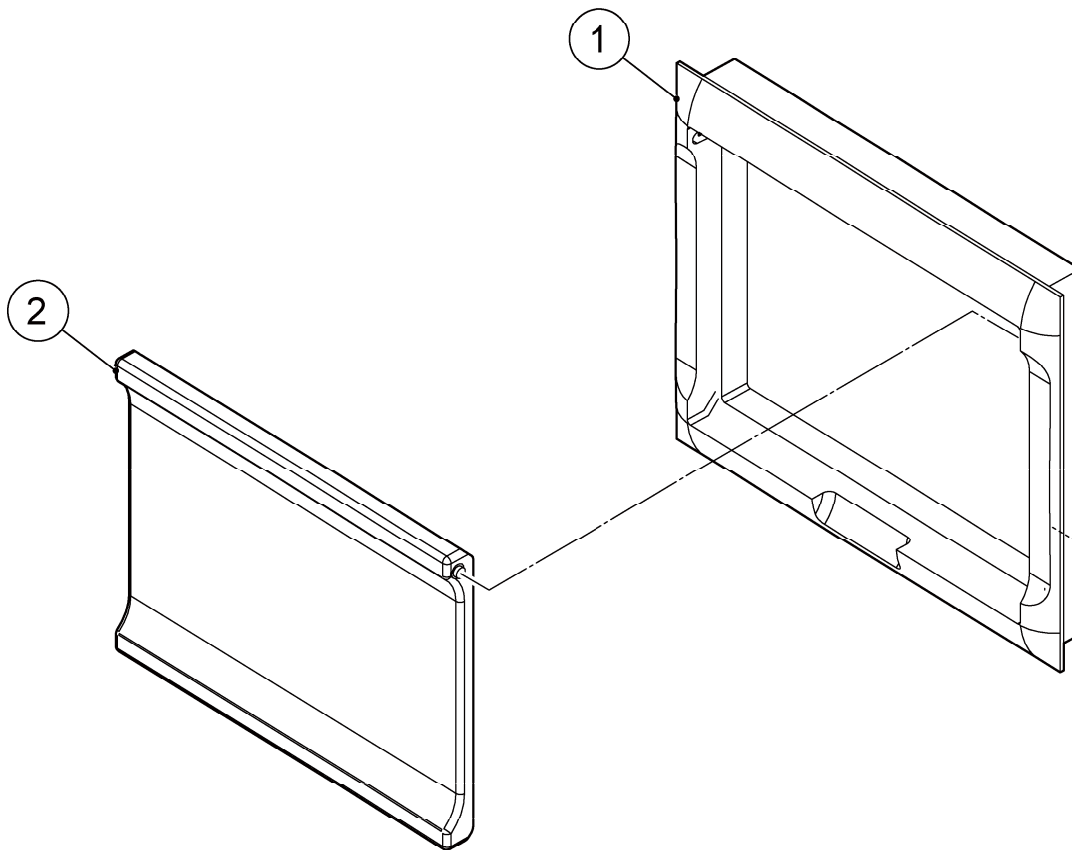

HE

MODEL: FM-750AKE(-SB) FM-750AKE-N(-SB) FM-1000AKE(-SB) FM-1000AKE-N(-SB)									
TITLE: F. WINDOW PANEL ASSY									
INDEX NO.	DESCRIPTION	MATERIAL OR MODEL NUMBER	PART NUMBER	REQ'D NUMBER					
				K-1 A-2	A-3 B-0	B-1 D-0	D-1 E-1	E-2	
1	WIND FRAME		232648-01	1	1	1	1	1	
2	WIND PANEL		232649-03	1	1	1	1	1	

DETAIL LABEL-TERMINAL

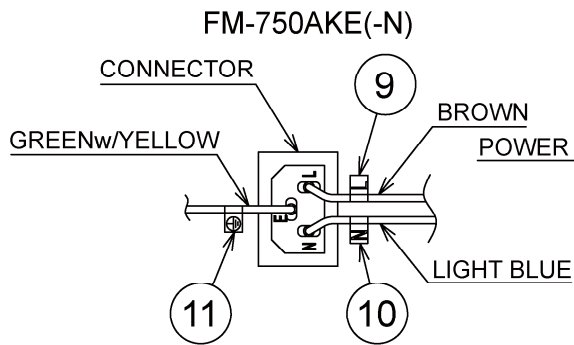

DETAIL LABEL-TERMINAL

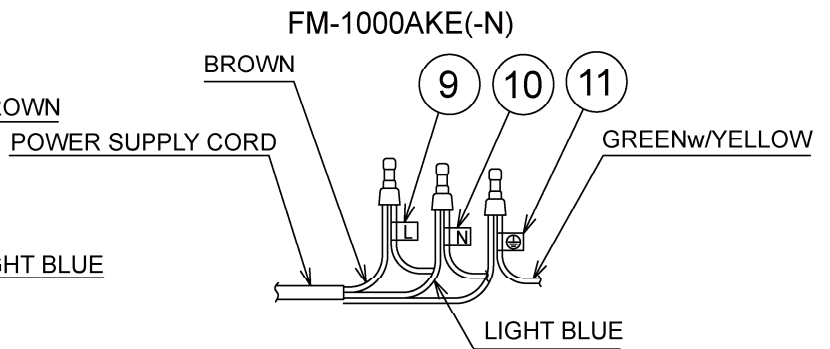

DETAIL CONTROL BOX

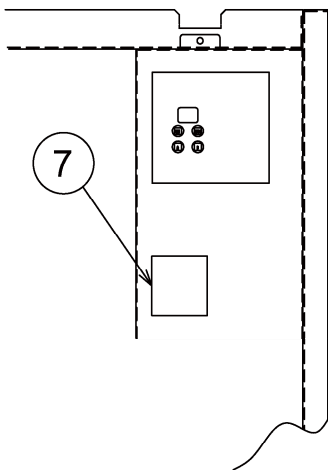

VIEW A

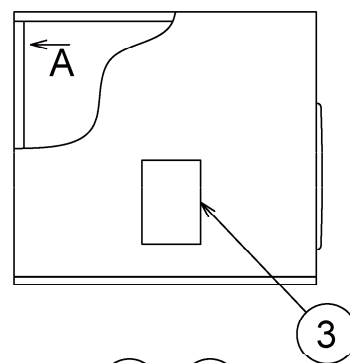
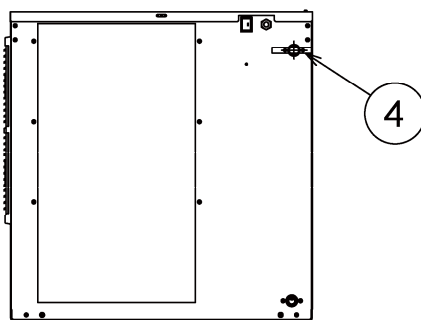
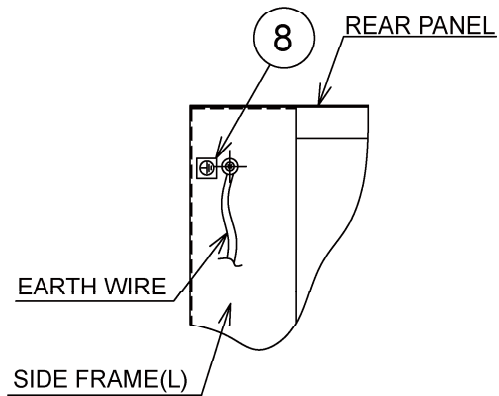

B

NAME PLATE

B →

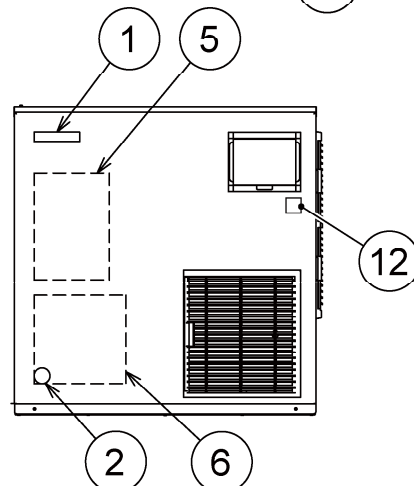
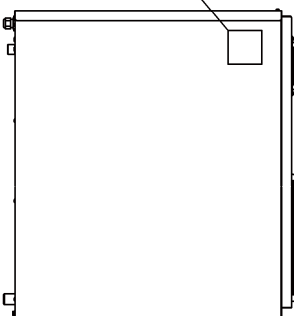

HE

MODEL: FM-750AKE(-SB) FM-750AKE-N(-SB) FM-1000AKE(-SB) FM-1000AKE-N(-SB)									
TITLE: G. LABEL LOCATION									
INDEX NO.	DESCRIPTION	MATERIAL OR MODEL NUMBER	PART NUMBER	REQ'D NUMBER					
				K-1 A-2	A-3 B-0	B-1 D-0	D-1 E-1	E-2	
1	EMBLEM		340842-01	1	1	1	1	1	
2	LABEL-PENGUIN		454387-01	1	1	1	1	1	
3	INSTRUCTION SHEET		374473L01	1	-	-	-	-	
			378049L01	-	-	-	1	1	
4	CAUTION-LABEL		452552-01	1	1	1	1	1	
5	LABEL - ERROR TABLE		259134L01	1	1	-	-	-	
6	WIRING LABEL	(F054, F054-C106)	259121L01	1	-	-	-	-	
			261350L01	-	1	-	-	-	
			262664L01	-	-	1	-	-	
			264599L01	-	-	-	1	1	
		(F054-C101, F054-C107)	(F055, F055-C106)	259122L01	1	-	-	-	-
				261351L01	-	1	1	1	1
		262667L01		-	-	1	-	-	
		264600L01		-	-	-	1	1	
		(F055-C101, F055-C107)							
		7	CAUTION LABEL - SERVICE		471180L01	1	1	1	1
8	LABEL-GROUND (B)		450452-02	1	1	1	-	-	
9	LABEL-TERMINAL		452379-03	1	1	1	-	-	
10	LABEL-TERMINAL		452379-04	1	1	1	-	-	
11	LABEL-TERMINAL		452379-05	1	1	1	-	-	
12	LABEL - HACCP		476519L01	1	1	1	1	1	

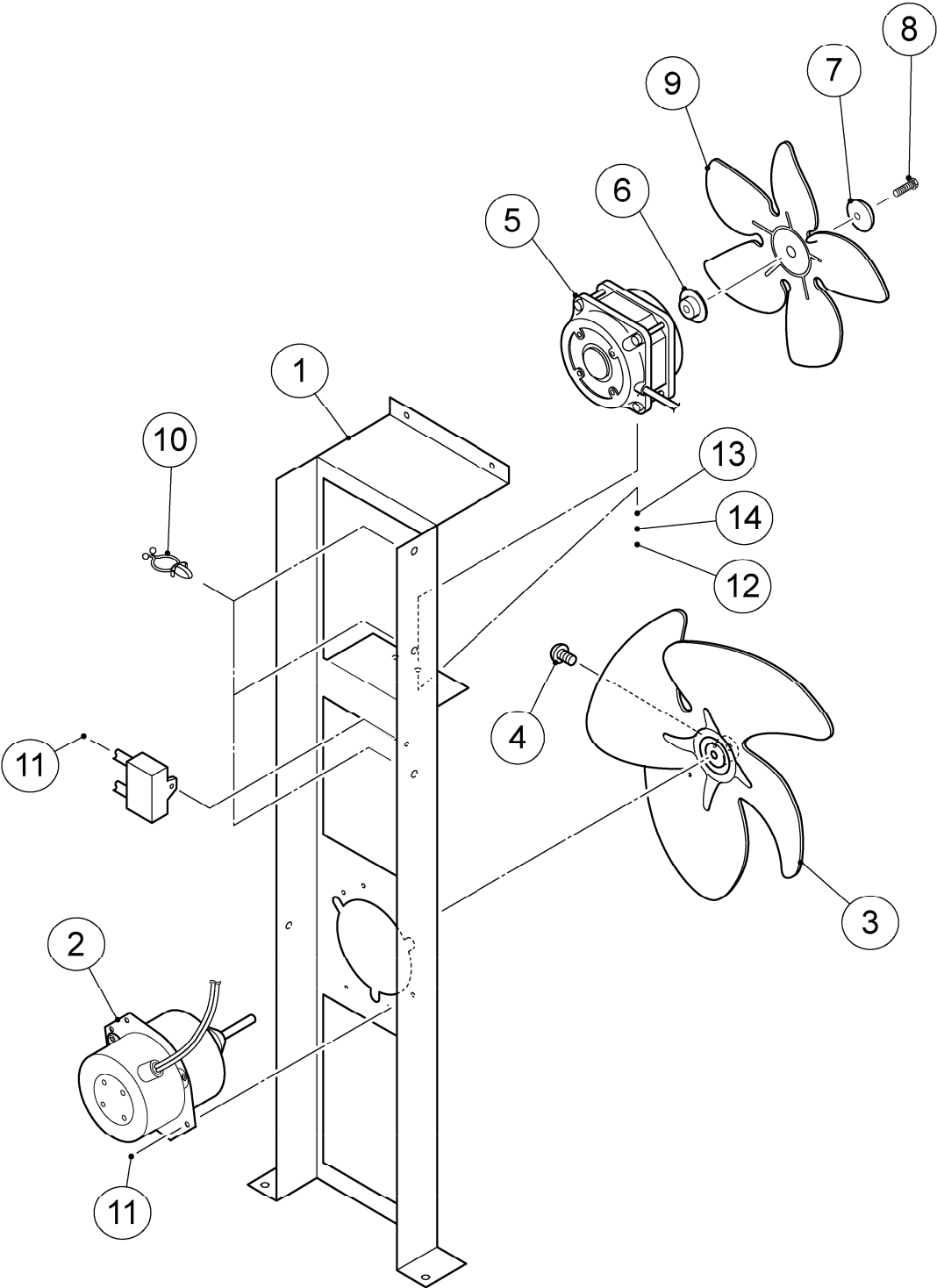

HE

MODEL: FM-750AKE(-N) FM-1000AKE(-N)								TITLE: H. FAN MOTOR ASSY			
INDEX NO.	DESCRIPTION	MATERIAL OR MODEL NUMBER	PART NUMBER	REQ'D NUMBER							
				K-1 A-2	A-3 B-0						
1	BRACKET-FAN MOTOR		241616-01	1	1						
2	FAN MOTOR		4Y2900-01	1	1						
3	FAN BLADE		417068-01	1	1						
4	SCREW		417068F01	1	1						
5	FAN MOTOR		451766-01	1	1						
6	VIBRATION PAD		451766F01	1	1						
7	WASHER/PAD		451766F02	1	1						
8	BOLT		451766F03	1	1						
9	FAN		354246-01	1	1						
10	CLAMP	No.249	427902-03	3	3						
11	PAN HEAD MACHINE SCREW (SPRING WASHER AND FLAT WASHER)		FSK0408S0	5	5						
12	NUT		FNH104S0	2	2						
13	FLAT WASHER		FWPL04S0	2	2						
14	SPRING WASHER		FWSP04S0	2	2						

FM-750AKE(-SB)
FM-750AKE-N(-SB)
FM-1000AKE(-SB)
FM-1000AKE-N(-SB)

H. FAN MOTOR ASSY

(B-1) and later

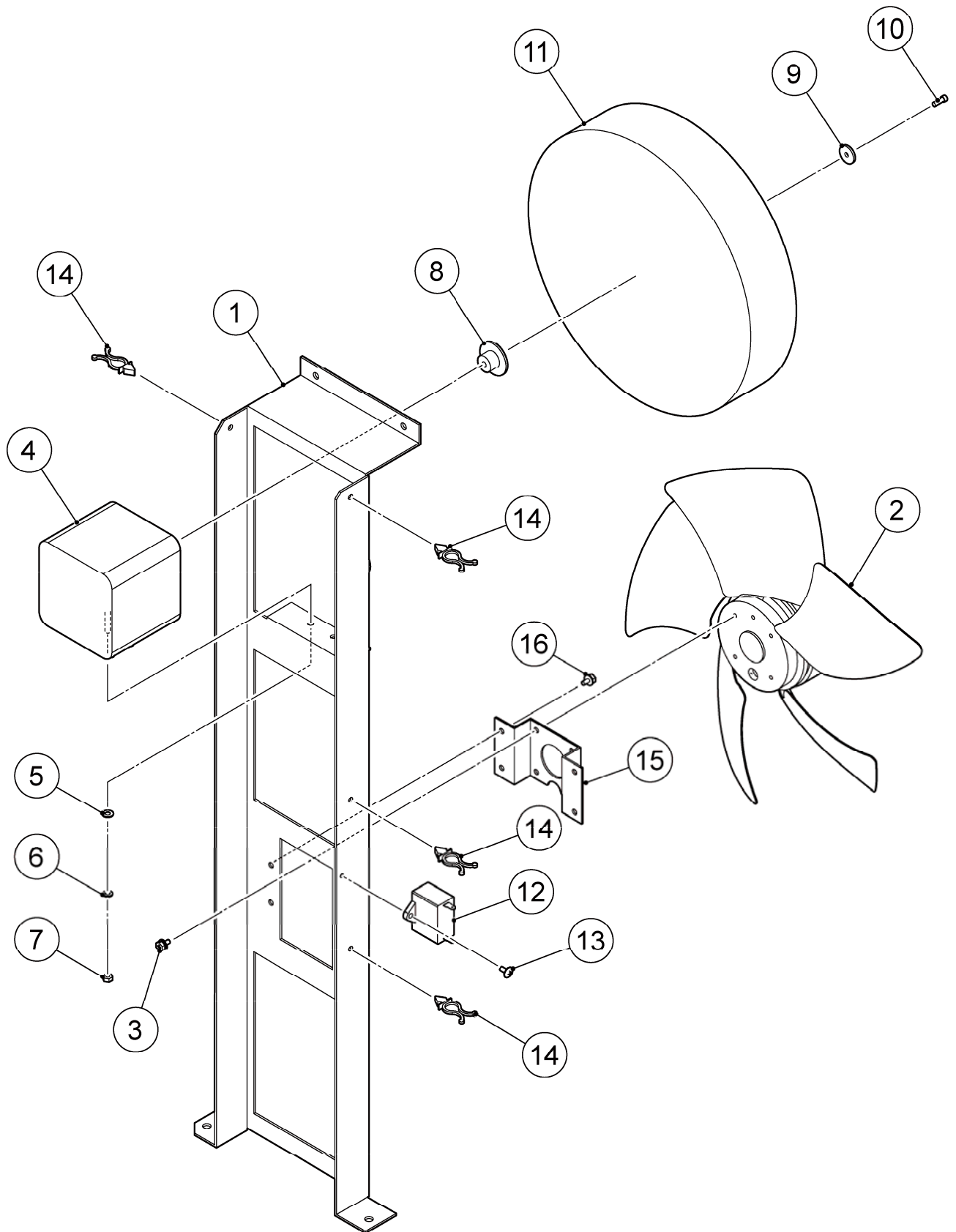

HE

MODEL: FM-750AKE(-SB) FM-750AKE-N(-SB) FM-1000AKE(-SB) FM-1000AKE-N(-SB)							
TITLE: H. FAN MOTOR ASSY							
INDEX NO.	DESCRIPTION	MATERIAL OR MODEL NUMBER	PART NUMBER	REQ'D NUMBER			
				B-1 D-0	D-1 E-1	E-2	
1	BRACKET(A)-FAN MOTOR		262066M01	1	1	1	
2	FAN MOTOR		P02394-01	1	1	1	
3	HEX HEAD BOLT (SPRING WASHER AND FLAT WASHER)		FBK0408S0	4	4	4	
4	FAN MOTOR		P02528-01	1	1	1	
5	FLAT WASHER		FWPL04S0	4	4	4	
6	SPRING WASHER		FWSP04S0	4	4	4	
7	NUT		FNH104S0	4	4	4	
8	VIBRATION PAD		P02528F01	1	1	1	
9	WASHER/PAD		P02528F02	1	1	1	
10	BOLT		P02528F03	1	1	1	
11	FAN BLADE		P02529-01	1	1	1	
12	CAPACITOR		P01865-01	1	1	1	
13	TRUSS HEAD MACHINE SCREW		FST0408F0	1	1	1	
14	CLAMP	No.249	427902-03	4	4	4	
15	BRACKET (B)-FAN MOTOR		476680M01	1	1	1	
16	HEX HEAD BOLT (SPRING WASHER AND FLAT WASHER)		FBK0408S0	4	4	4	

FM-750AKE(-SB)
FM-750AKE-N(-SB)
FM-1000AKE(-SB)
FM-1000AKE-N(-SB)

J. ACCESSORIES

(K-1) and later

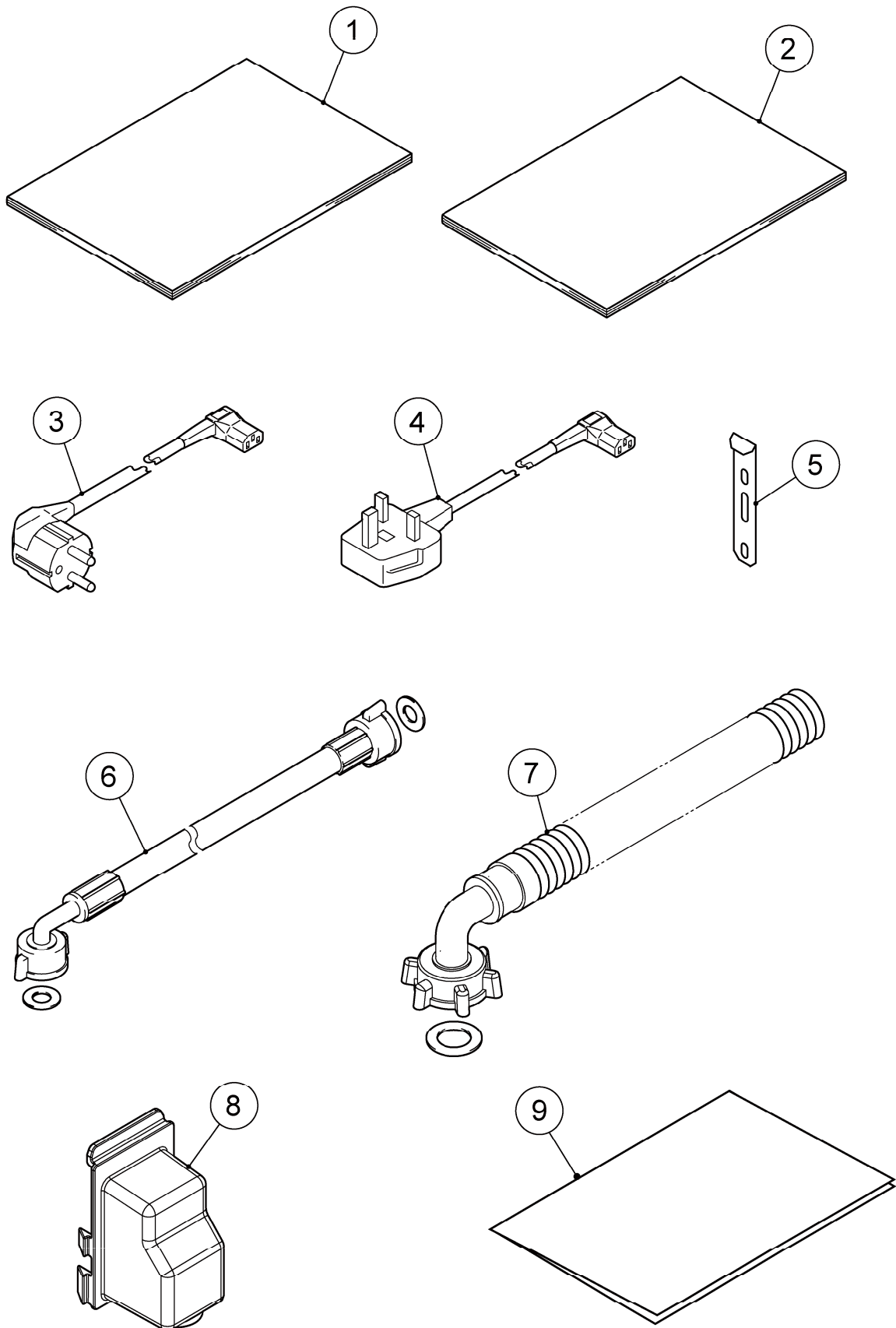

HE

MODEL: FM-750AKE(-SB) FM-750AKE-N(-SB) FM-1000AKE(-SB) FM-1000AKE-N(-SB)								
TITLE: J. ACCESSORIES								
INDEX NO.	DESCRIPTION	MATERIAL OR MODEL NUMBER	PART NUMBER	REQ'D NUMBER				
				K-1 A-2	A-3 B-0	B-1 D-0	D-1 E-1	E-2
1	INSTRUCTION MANUAL		L1F054203	1	1	1	1	1
2	INSTALLATION MANUAL		L2F054202	1	1	1	-	-
			L2F054203	-	-	-	1	1
3	POWER SUPPLY CORD	CONT Plug (F054, F054-C101, F054-C106, F054-C107)	P03362-01	1	1	1	1	1
4	POWER SUPPLY CORD	UK Plug (F054, F054-C101, F054-C106, F054-C107)	P03363-01	1	1	1	1	1
5	UNIVERSAL BRACE		4A0363-01	2	2	2	2	2
6	INLET HOSE		P03534-01	1	1	1	1	1
7	OUTLET HOSE		452365-01	1	1	1	1	1
8	COVER-CONNECTOR	(F054, F054-C101, F054-C106, F054-C107)	2X0271P01	-	-	1	1	1
9	INSTRUCTION MANUAL		122234L01	1	1	1	1	1

(S-9165)

FM-750AKE(-N)
FM-1000AKE(-N)

K. BAND ASSY

(A-3) to (D-0)

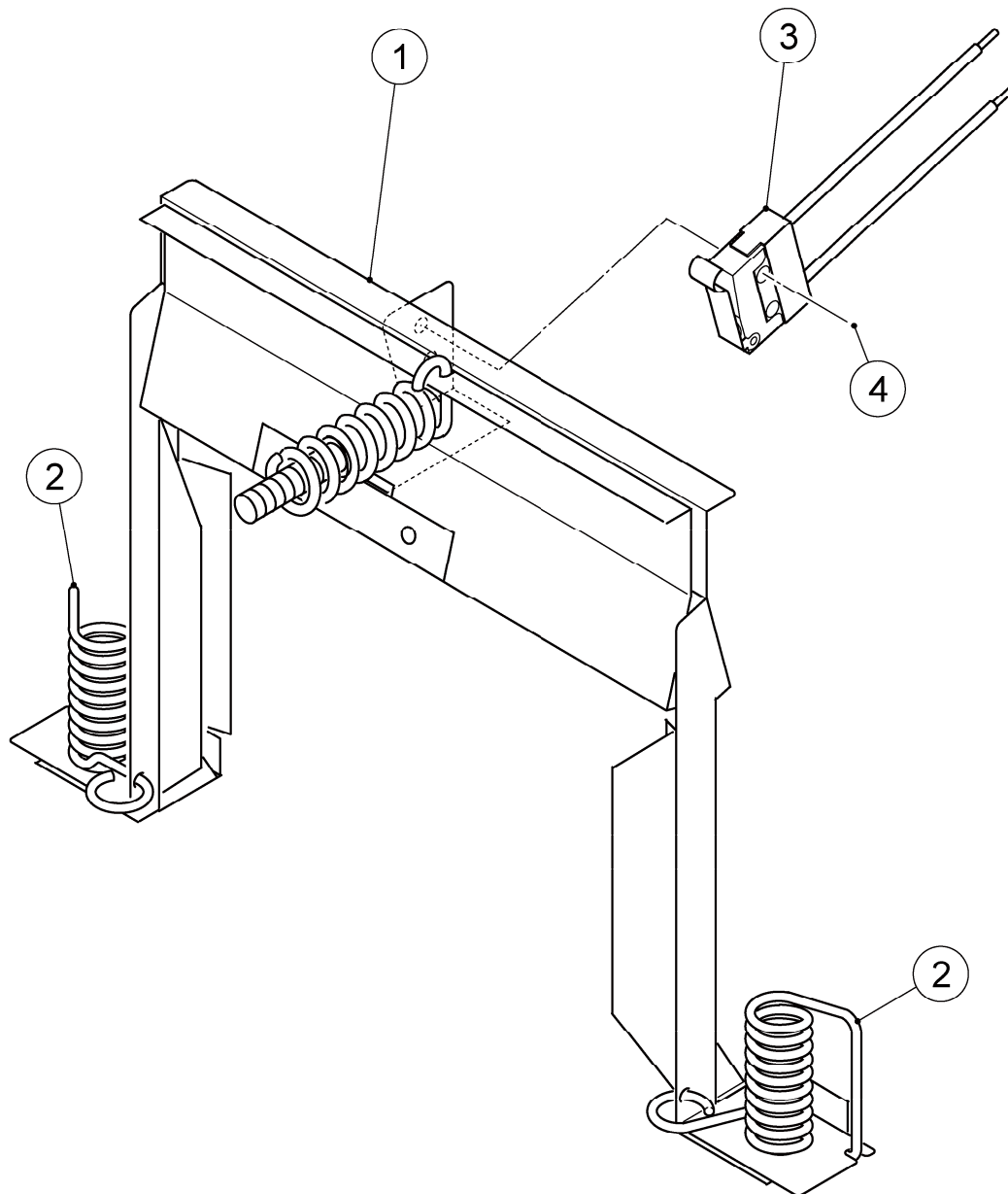

HE

MODEL: FM-750AKE(-N) FM-1000AKE(-N)							
TITLE: K. BAND ASSY(S-9165)							
INDEX NO.	DESCRIPTION	MATERIAL OR MODEL NUMBER	PART NUMBER	REQ'D NUMBER			
				A-3 B-0	B-1 D-0		
1	BAND (A)		348305G01	1	1		
2	SPRING (A)		459997-01	2	2		
3	MICROSWITCH	ABS1624318	443992-02	1	1		
4	PAN HEAD MACHINE SCREW (SPRING WASHER AND FLAT WASHER)		470416-01	2	2		

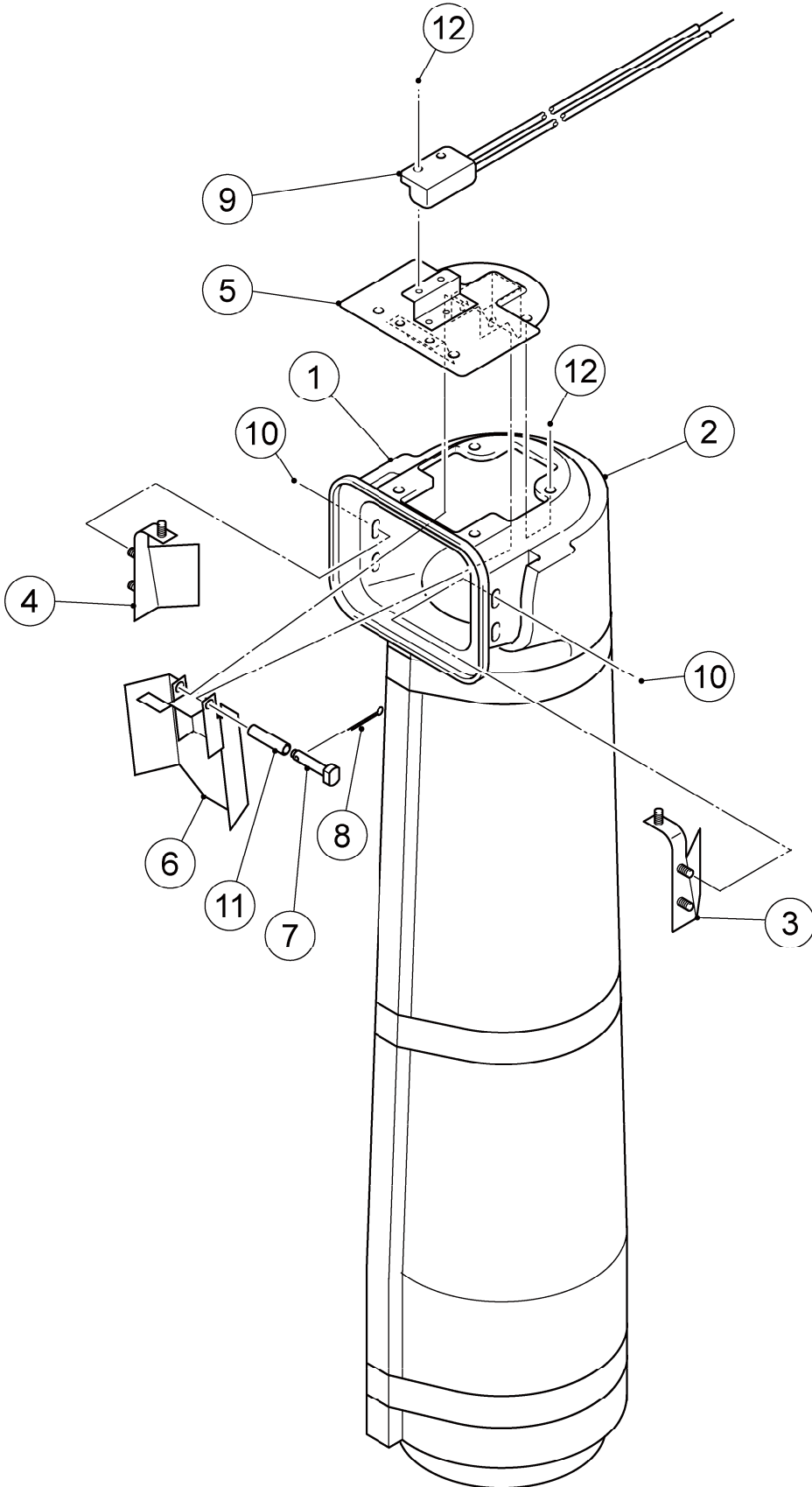

FM-750AKE(-SB)
FM-750AKE-N(-SB)
FM-1000AKE(-SB)
FM-1000AKE-N(-SB)

L. CHUTE ASSY

(D-1) and later

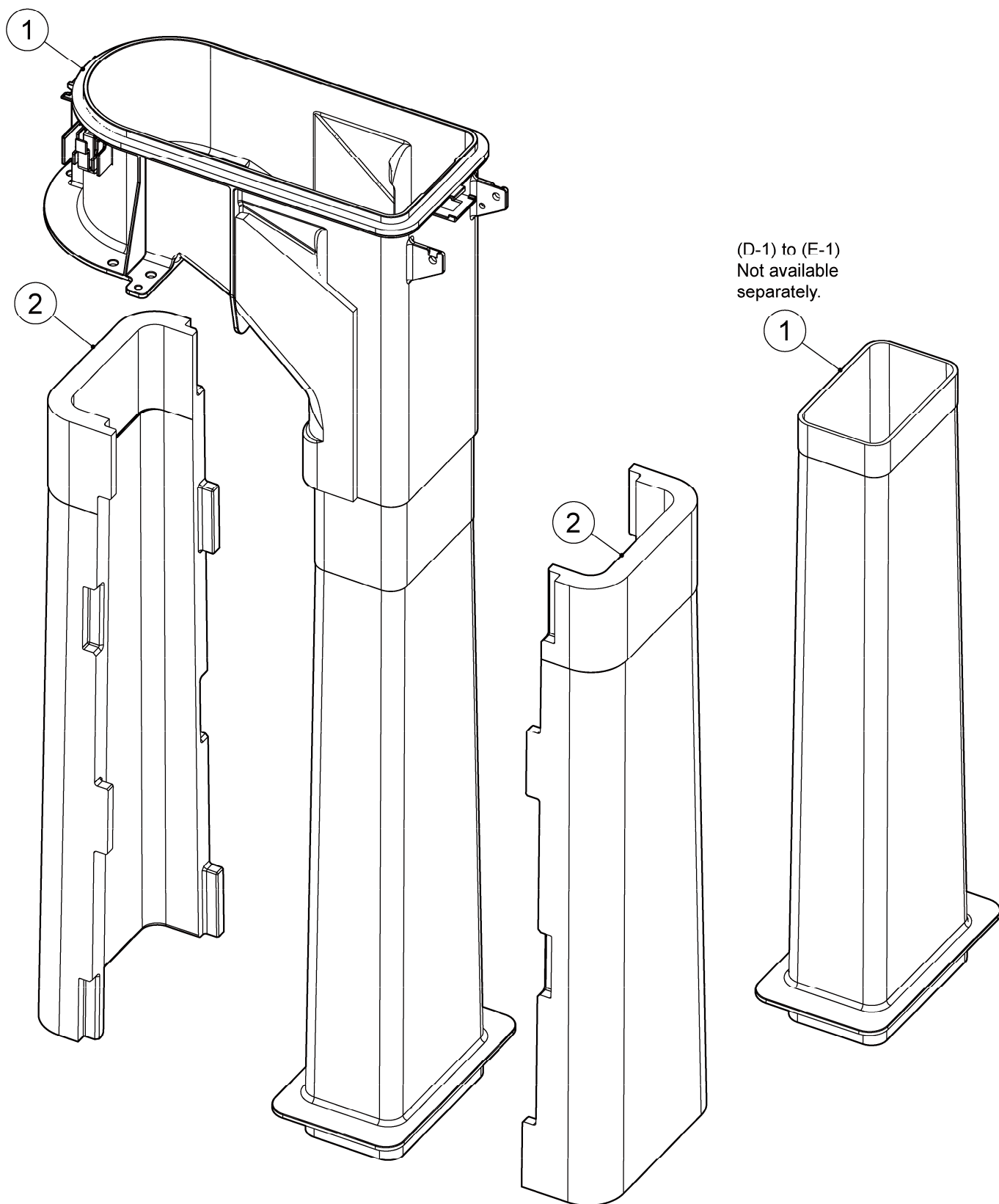

HE

MODEL: FM-750AKE(-SB) FM-750AKE-N(-SB) FM-1000AKE(-SB) FM-1000AKE-N(-SB)							
TITLE: L. CHUTE ASSY							
INDEX NO.	DESCRIPTION	MATERIAL OR MODEL NUMBER	PART NUMBER	REQ'D NUMBER			
				A-3 B-0	B-1 D-0	D-1 E-1	E-2
1	CHUTE		214823-01	1	1	-	-
		Integrated with SPOUT - 70 Not available separately. Order SPOUT - CHUTE 70 (268064G02)		-	-	1	-
	SPOUT - CHUTE 70		268064G02	-	-	-	1
2	INSULATION-CHUTE		235310-01	1	1	-	-
			263903P02	-	-	2	2
3	BAFFLE - CHUTE (A)		325122G01	1	1	-	-
4	BAFFLE - CHUTE		325123G01	1	1	-	-
5	BIN CONTROL		353918G01	1	1	-	-
6	ACTUATOR		436848G05	1	1	-	-
7	SHAFT		458813-01	1	1	-	-
8	SPLIT PIN		711SP1612	1	1	-	-
9	PROXIMITY SWITCH		4A2033-01	1	1	-	-
10	WING NUT		FNW204S0	6	6	-	-
11	TUBE		461623-01	1	1	-	-
12	TRUSS HEAD MACHINE SCREW		FST0406S0	4	4	-	-